

TENUE DE SOIRÉE

La gamme du bon goût

Collection 2017



JANV2017

CATLUX07

Des idées ...
FIRPLAST
pour vous « emballer »

PACK POUR LE FUTUR

30 ans

Dear Valued Customers,

For the past 30 years, Firplast has been catering to all of your catering needs with fresh, innovative ideas.

We are proud to provide you with more solutions that will transport you to new creative heights each and every day!

After introducing our new on-line ordering system, with its personalized profiles, and welcoming both the mes-verrines.com site and “La Vaiselle d’Eugénie [Eugenie’s Tableware]” (p.73) into our company, today we are happy to present our exciting catalogue for 2017: Tenue de Soirée [Putting on the Ritz]!

Because Firplast cares about protecting the environment, we are offering a full range of ecological and completely biodegradable products in this year’s catalogue (p.20). Look for the Ladybird symbol to find our Vision Verte [Seeing Green] range and help make a bright future with Firplast!

Discover the latest collections created especially for you by our great team of designers! From the pure lines of our very complete Esmeralda range (p.10) to the gastronomical tradition of our “Frenchy folies” [Flight of French Fancy] range (p.12), you will find the products you need to create the presentations of your dreams.

Our transportation solutions and our adaptable tray systems are even more original and enticing (p.22), of course.

And, don’t forget that our team is always ready to help you with every aspect of your packaging needs, from the early planning stages to adding the personalized touches that give your projects that special polish!

The Team 

Queridos clientes,

Firplast cumple 30 años dedicados al desarrollo de ideas de packaging atractivas.

Nos sentimos orgullosos de poder ofrecerles nuevas soluciones para ayudarles en el día a día.

Tras la puesta en funcionamiento de nuestra nueva página web de compra en línea –donde podrán disponer de un espacio de cliente personalizado– y la incorporación a nuestro grupo de las páginas web mes-verrines.com y La Vaiselle d’Eugénie (p.73), le presentamos la edición 2017 de nuestro catálogo «Tenue de Soirée».

En Firplast somos conscientes de la actual preocupación sobre la protección del medioambiente y, por ello, les ofrecemos una gama eco-responsable completamente biodegradable (p.20). En esta edición, todos los productos en los que figura una mariquita forman parte de nuestra línea ecológica «Vision Verte». Por un futuro mejor.

Les invitamos a descubrir las nuevas colecciones que nuestros diseñadores han creado para ustedes. Desde la pureza de líneas de la completa gama «Esmeralda» (p.10) al respeto por la tradición gastronómica en la serie «frenchy folies» (p.12), déjense llevar por la imaginación, nuestros productos les satisfarán.

Además, disponemos de soluciones para el transporte y para eventos que requieran rapidez y dinamismo con nuestras originales y atractivas bandejas para comida (p.22).

Y recuerde que, desde el diseño a la personalización, nuestro departamento de comunicación está siempre a su servicio para ayudarles a desarrollar sus proyectos de packaging.

El equipo 

INGENIERIE

RECHERCHES & DEVELOPPEMENT

Nous sommes là pour répondre à tous vos besoins ainsi qu'à votre cahier des charges point par point.

Nous créons un design innovant, attrayant, qui facilite l'utilisation de votre produit.

Ainsi, le développement ingénierie permet de réaliser toutes vos envies.

Enfin, nous concrétisons vos projets à l'aide de plans techniques et rendus réalistes en 3D.

Pour toute commande, nous vous offrons la possibilité de visualiser les projets grâce au prototypage.



L'IDÉE



LA CONCEPTION



LA FABRICATION



LA QUALITÉ

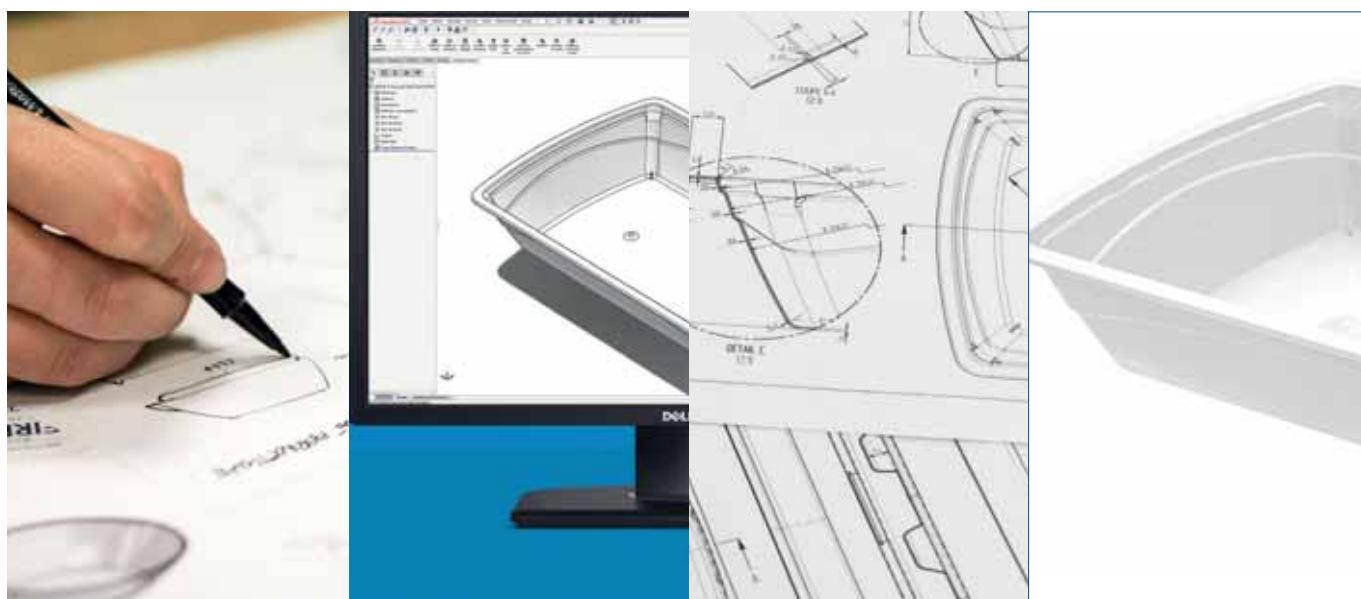

CREATION GRAPHIQUE

PERSONNALISATION

Nous analysons votre cahier des charges : le type de produit à personnaliser, la quantité souhaitée, le délais, le visuel à imprimer et le nombre de couleurs.

Nous créons pour vous les bons à tirer sur gabarit en établissant une recherche colorimétrique, formelle et typographique.

Après validation sur épreuve papier, nous permettons à vos projets de voir le jour.

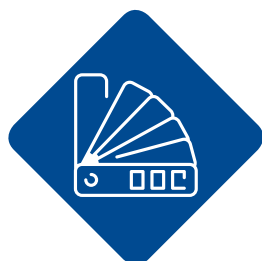
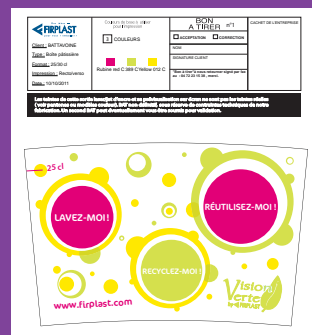
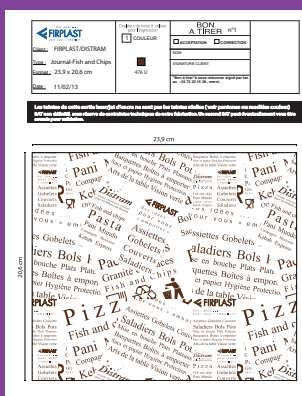

LA PERSONNALISATION



LA DISTRIBUTION

E-COMMERCE

MISE EN LIGNE

Pour vous, nous organisons la présentation de nos produits, leur mise en situation, leurs caractéristiques techniques, leurs conditionnements et leurs «Plus».

Nous mettons à jour l'actualité de nos produits afin de vous offrir un maximum de choix et de nouveautés.

Enfin, nous optimisons les moteurs de recherches et les options de navigation pour faciliter votre requête.



Sommaire

VERRINES UNIVERSE

1. COLLECTION ESMERALDA
2. COLLECTION O'RONDE

P. 8



VERRINES VISION VERTE

1. COLLECTION PULP INSTINCT
2. COLLECTION WOOD MOOD

P. 18



VERRINES FRENCHY FOLIES

1. VERRE, PP, PS, FAYENCE, PORCELAINE

P. 26

PRÉSENTATION

1. PRÉSENTATION

P. 42



NON-STOP - PLATEAUX REPAS

1. COLLECTION MACO POLO
2. COLLECTION NON STOP - «FAMOUS BREAK»
3. COLLECTION VISION VERTE - «FAMOUS BREAK»
4. COLLECTION NON STOP - «PLATEAU BENTO»
5. COLLECTION ESMERALDA
6. COLLECTION VAGUE
7. COLLECTION «NON STOP»
8. COLLECTION VISION VERTE
9. PLATEAU SCELLABLE
10. PLATEAU SANDARD
11. PLATEAU BARQUETTE
12. BOÎTE SNACKING

P. 50

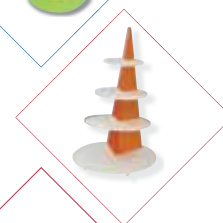

ASSIETTES

1. ASSIETTE «GOUTTE D'EAU»
2. ASSIETTE «JADE»
3. ASSIETTE VAGUE
4. ASSIETTE TOKUDAÏ
5. ASSIETTE ESMERALDA
6. ASSIETTE FOU DES ANNÉES 80 !
7. ASSIETTE COLLECTION «WOOD MOON»
8. ASSIETTE VISION VERTE
9. ASSIETTE COCKTAIL

P. 90

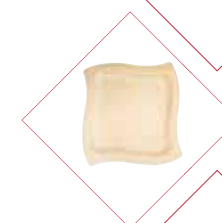

SALADIERS ET MINI-POTS

1. SALADIERS ET MINI POTS
2. SALADIERS ET MINI POTS «VISION VERTE»
3. BOITE SUSHI ET BOL
4. SALADIER CARTON

P. 106

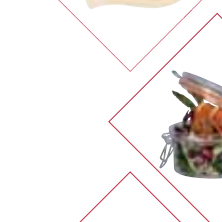

COUPES DESSERTS

1. COUPES DESSERTS

P. 118

COUVERTS - SACHETS COUVERTS ET ACCESSOIRES

1. COUVERTS VISION VERTE
2. COLLECTION «FRENCHY FOLIES»
3. COLLECTION EMERALDA
4. COLLECTION WOOD MOOD
5. COUVERTS LUXE
6. COUVERTS À DESSERTS
7. SACHETS COUVERTS

P. 124

VERRES

1. FLÛTE À CHAMPAGNE
2. VERRE À VINS ET VERRE À DÉGUSTATIONS
3. VERRE CRISTAL
4. VERRE CARTON ONDULÉ
5. VERRE BALLON DE RUGBY
6. PORTE VERRE ET VERRE CONIQUE
7. VERRE CONSIGNÉ
8. VERRE RÉUTILISABLE

P. 138

SERVIETTES ET NAPPES

1. SERVIETTE OUATE BLANCHE
2. SERVIETTE ET DISTRIBUTEUR
3. SERVIETTE OUATE SÈCHE
4. SERVIETTE ÉCOLOGIQUE 100% FIBRE RECYCLÉE
5. NAPPE BLANCHE EN ROULEAU
6. NAPPE FORMAT BLANC
7. SET COULEUR
8. CHEMIN DE TABLE VOIE SÈCHE
9. JUPONNAGE NON-TISSÉ
10. NAPPE VOIE SÈCHE
11. SURNAPPE VOIE SÈCHE - TÊTE À TÊTE VOIE SÈCHE

P. 152

SOLUTION TRANSPORT

1. PLATEAU FAST FOOD
2. CAISSES TRAITEUR
3. PLATEAU RÉCEPTION
4. PLATEAU FLÛTES
5. PLATEAU SUPER-POSABLE
6. LA BOITE DE TRANSPORT
7. SAC CABAS ET SAC À EMPORTER
8. SOLUTION DOGGYBAG

P. 162

LÉGENDE



Compatible
avec Four traditionnel



Compatible avec Micro-onde



Matière biodégradable



Verrines universes

◆ *Esmeralda*

Depuis les grandes pyramides, on attendait une révolution dans les formes. Grâce à la collection esmeralda de FIRPLAST, c'est chose faite ! Laissez vous porter par la magie d'un design sans cesse réinventé.

◆ *O Ronde*

La Terre est bleu comme une orange ! Paul Eluard le savait, la sphère fait partie de tous les préparations : Alchimiques, culinaires, artistiques. Nous l'avons adaptée, à vous d'inventer la suite.



Verrines : Des constructions de génies !

Collection «Esmeralda»



8450001TV/C



8450002TV/C



8450003TV/C



846004TV



8460005TV



8450001TV/C

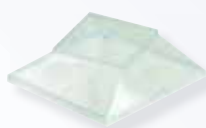

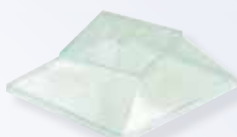

8450002COV/C





8450003COV/C

VERRINE «VENISE» PS 6 CL «VENISE» PS square verrine Vasito cuadrado «VENISE» PS

 55x55x55 mm - 6 cl
 8450001TV/C
 600 (10x60)





COUVERCLE POUR VERRINE CARRÉE VENISE PS lid / Tapa PS

 55x55x55 mm
 8450001COV
 1000 (2x500)







VERRINE «VENISE» PS 18 CL «VENISE» PS square verrine Vasito cuadrado «VENISE» PS

 77x77x77mm
 18 cl
 8450003TV/C
 480 (12x40)





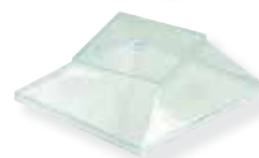

COUVERCLE PS PS lid / Tapa PS

 79x79x32 mm
 -
 8450003COV/C
 480 (12x40)







VERRINE «VENISE» PS 12 CL «VENISE» PS square verrine Vasito cuadrado «VENISE» PS

 67x67x70 mm
 12 cl
 8450002TV/C
 480 (12x40)



COUVERCLE PS PS lid / Tapa PS

 70x70x25 mm
 -
 8450002COV/C
 480 (12x40)

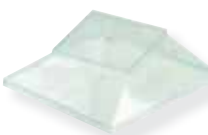

VERRINE «ICE CUBE» PS TRANSPARENT VERT H4,5 CM «ICE CUBE» PS transparent green square verrine Vasito cuadrado transparente verde «ICE CUBE» PS

 L5xH4,5 cm
 846004TV
 1200 (50x24)



VERRINE «ICE CUBE» PS TRANSPARENT VERT H6,5 C CM «ICE CUBE» PS transparent green square verrine Vasito cuadrado PS transparente verde «ICE CUBE»

 L5xH6,5 cm
 8460005TV
 600 (50x12)



Dimensions
Dimensions



Capacité
Capacity



Référence
Reference



Conditionnement
Packaging

Verrines : Une courbure parfaite !...

Collection «Esmeralda»



843003TV

8420004TV

8430002TV

8420005TV

8480068

8480062

8480078



8430003COV



8430002COV

VERRINE «COROLLE» PS TRANSPARENT VERT

«COROLLE» PS transparent green verrine
Vasito «COROLLE» PS transparente verde



8-9 cl

843003TV

300 [20x15]



COUVERCLE PS

PS lid / Tapa PS



70x65 mm

8430003COV

1000 [2x500]



VERRINE TRIANGLE «SEVILLE» PS TRANSPARENT

«SEVILLE» PS transparent green triangle verrine
Vasito «SEVILLE» triangular PS transparente verde



7 cl

8430002T

600 [60x10]



COUVERCLE PS

PS lid / Tapa PS



48x48 mm

8430002COV

1000 [2x500]



VERRINE MINI-COUPÉ COROLLE 34 CL PS TRANSPARENT

MINI-COUPÉ MINI-COUPÉ COROLLA 68 CC
VERRINE MINI Coupé COROLLA 68 CC

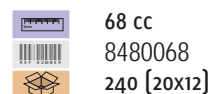

68 cc

8480068

240 [20x12]



VERRINE «CYLINDRIQUE» PS TRANSPARENT VERT

«CYLINDRIQUE» PS transparent green verrine
Vasito «CYLINDRIQUE» PS transparente verde



7 cl

8420004TV

600 [30x20]



VERRINE MINI-COUPÉ STYLE 31 CL PS TRANSPARENT

MINI-COUPÉ MINI-COUPÉ COROLLA 31 CL
VERRINE MINI Coupé COROLLA 62 CC

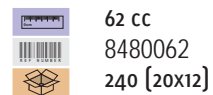

62 cc

8480062

240 [20x12]



VERRINE «LONGUE DRINK» PS TRANSPARENT VERT

«LONGUE DRINK» PS transparent green tube verrine
Vasito «LONGUE DRINK» PS transparente verde



12 cl

8420005TV

360 [30x12]



VERRINE MINI-COUPÉ SMART 39 CL PS TRANSPARENT

SMART SMALL CUT SMALL 39 CL
PS TRANSPARENT
VERRINE MINI COUPE SMART- 39 CL
PS TRANSPARENTE

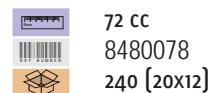

72 cc

8480078

240 [20x12]





Verrines : Arrondir les angles !

Collection «Esmeralda»



VERRINE PS «PARIS»

«PARIS» PS Verrine
Vasito «PARIS» PS

 2-3 cl
 8410003
 1000 {20x50}



VERRINE PS «L.A.»

«L.A.» PS Verrine
Vasito «L.A.» PS

 10-11 cl
 8410007
 1000 {20x50}



VERRINE PS «ST MORITZ»



«ST MORITZ» PS Verrine
Vasito «ST MORITZ» PS

 4-5 cl
 8410008
 1000 {40x25}



COUVERCLES PS POUR VERRINES «L.A.»

COVERS FOR PS VERRINES «L.A.»
CUBIERTAS PARA PS VERRINES «L.A.»

 8410007COV (pour L.A.)
 2000 {2x1000}



COUVERCLES PS POUR VERRINES «ST MORITZ»

COVERS FOR PS VERRINES «L.A.»
CUBIERTAS PARA PS VERRINES «L.A.»

 8410008COV (pour ST MORITZ)
 2000 {2x1000}



VERRINE COCKTAIL PS



PS Cocktail Verrine
Vasito Cocktail PS

 20-24 cl
 8410010
 1000 {25x40}



VERRINE PS «MIAMI»

«MIAMI» PS Verrine
Vasito «MIAMI» PS

 7-8 cl
 8410009
 800 {16x50}



COUVERCLES PS POUR VERRINES



COVERS FOR PS VERRINES
CUBIERTAS PARA PS VERRINES

 8410010COV (pour L.A.)
 2000 {2x100}



COUVERCLES PS POUR VERRINES «MIAMI»

COVERS FOR PS VERRINES «MIAMI»
CUBIERTAS PARA PS VERRINES «MIAMI»

 8410009COV (pour Miami)
 2000 {20x100}



Dimensions
Dimensions



Capacité
Capacity



Référence
Reference



Verrines : Mini verres, maxi créativité !

Collection «Esmeralda»



8430001T



8430001COV



0915030



09150005



8420004

VERRINE «5TH AVENUE» PS TRANSPARENTE

«5th AVENUE» PS Transparent Verrine
Vasito «5th AVENUE» PS transparente



COUVERCLE PS

PS lid / Tapa PS

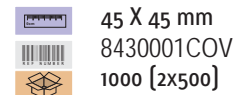

VERRINE «CÔNE» PS TRANSPARENTE

PS Transparent Verrine
Vasito PS transparente



PRÉSENTOIR PLASTIQUE 12 VERRINES (5 PRÉSENTOIRS + 60 VERRINES)

Display Tray 12 Verrines (5 DISPLAY + 60 LOCKS)
Expositor 12 vasitos (5 + 60 VERRINES pantalla)

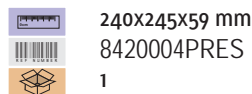

PRÉSENTOIR PLASTIQUE «CRISTAL» 12 VERRINES

«CRISTAL» Display Tray 12 Verrines
Expositor Cristal 12 vasitos

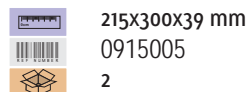

sur commande
to order / de encargo

PLATEAU DE PRÉSENTATION ET DE TRANSPORT POUR 30 VERRINES (VENDU SANS VERRINES)

Display tray for 30 verrines (verrines sold separately)
Bandeja 30 vasitos (no incluidos)

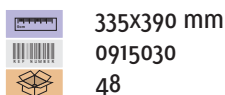

EMPLIABLE

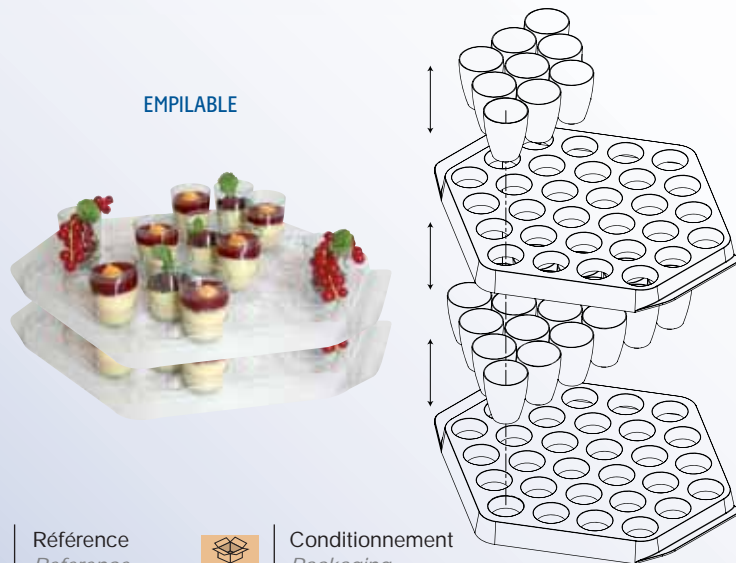

Verrines : Prendre la tangeante !

Collection «Esmeralda»



8440011T



40267TV

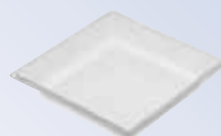

11327070

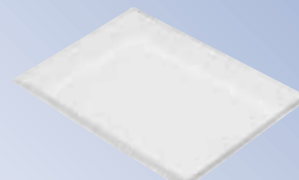

1132070115



8440011COV



40267TVCOV



11327070COV

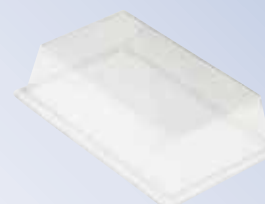

1132070115COV

VERRINE CUBE 4 CL TRANSPARENTE

Small glass cube 4 seamless CL
Pequeño cubo de vidrio transparente 4 CL

4,5xL2,1xH2,3cm - 4 cl

8440011T
 300 (30x10)



COUVERCLE PVC

PS lid for Transparent Green Dish Verrine
Tapa para recipiente PS transparente verde

L4,3xP2,1xH1,2 cm

8440011COV
 1000 (2x500)



VERRINE «LUXAIR» 70x70 mm PET

PET «LUXAIR» verrine / Vasito «LUXAIR» PET

70x70 mm
 11327070
 500

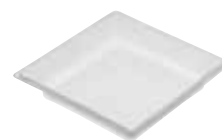

COUVERCLE PET

PET lid / Tapa PET

70x70
 11327070COV
 500



VERRINE «PLAT» + ANSES PS TRANSPARENT VERT - 8 cl

PS transparent green dish verrine + Handles
Recipiente con asas PS transparente verde

6,7xL5xH3 cm - 8 cl

40267TV
 576 (24x24)



COUVERCLE PS

PS lid for Transparent Green Dish Verrine
Tapa para recipiente PS transparente verde

7x5 cm

40267TVCOV
 576 (24x24)



VERRINE «LUXAIR» 70x115 mm PET

PET «LUXAIR» verrine / Vasito «LUXAIR» PET

70x115 mm
 1132070115
 500



COUVERCLE PET

PET lid / Tapa PET

70x115 mm
 1132070115COV
 500



Dimensions
Dimensions



Capacité
Capacity



Référence
Reference



Conditionnement
Packaging

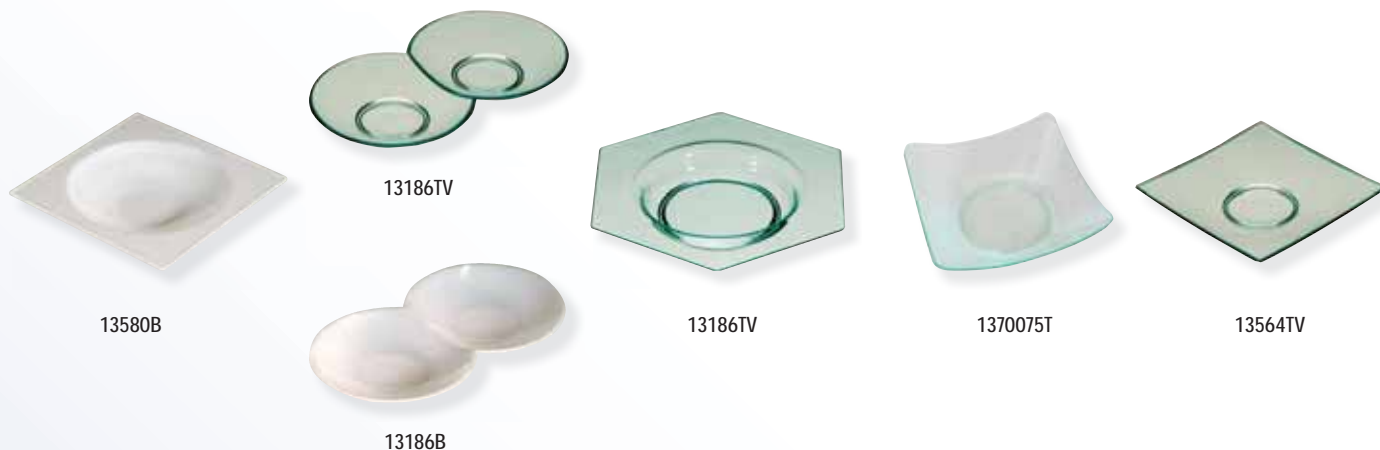

Verrines : Formes de génie !

Collection «Esmeralda»



ASSIETTE PS «ST BARTH» BLANCHE



«ST. BARTH» PS white plate
Platito «ST. BARTH» blanco

 80x80x12,4 mm
 13580B
 500 (10x50)



ASSIETTE PS «MAJORQUE» TRANSPARENT VERT

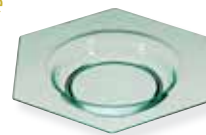

«MAJORQUE» PS transp. Green plate
Platito «MAJORQUE» transp. verde

 92x80x10 mm
 13392TV
 500 (10x50)



ASSIETTE PS «SPLIT» TRANSPARENT VERT



«SPLIT» PS transparent green plate
Platito «SPLIT» PS transparente verde

 86x49x10 mm
 13186TV
 500 (10x50)



MINI-PLAT PS «KEY WEST» TRANSPARENT



«KEY WEST» PS transp. green mini dish
Plato cóctel «KEY WEST» PS transp. verde

 76x76 mm
 1370075T
 500 (10x50)



ASSIETTE PS «SPLIT» BLANCHE

«SPLIT» PS white plate
Platito «SPLIT» PS blanco

 86x49x10 mm
 13186B
 500 (10x50)



Dimensions
Dimensions



Capacité
Capacity



Référence
Reference



Conditionnement
Packaging

Verrines : Mettre les bouchées doubles !

Collection «Esmeralda»



153125TV



153125N



153125B



1544310



1544110/C





1544210/C



1154010





CUILLÈRE «MONACO» TRANSPARENT VERT PS
 «MONACO» PS transparent green appetiser spoon
 Cuchara «MONACO» PS transparente verde

 125x35x34 mm
 153125TV
 500 (10x50)



CUILLÈRE «TAPAS» VERT TRANSPARENT PS
 «TAPAS» PS transparent green spoon
 Cuchara para «TAPAS» PS transparente verde

 105 x 45 x 25 mm
 1544310
 1000 (10x100)



Variez les plaisirs !
 Existe aussi en noir et en blanc



153125N





153125B



CUILLÈRE «TAPAS» PS BLANCHE
 CUCHARA PARA «TAPAS» PS BLANCA



NOUVEAU

 96 X 41 X 30 MM
 1544110/C
 2000 (20X100)



CUILLÈRE «TAPAS» PS NOIRE
 CUCHARA PARA «TAPAS» PS NEGRO



NOUVEAU

 96 X 41 X 30 MM
 1544210/C
 2000 (20X100)



VERRINE PULPE «FEUILLE»
 «LEAF-SHAPED» cellulose verrine
 Recipiente de pulpa prensada «HOJA»



 105 x 51 x 29 mm
 1154010
 100 (40x25)



Retrouvez toutes nos verrines «Vision verte» p.19



Dimensions
 Dimensions



Capacité
 Capacity



Référence
 Reference



Conditionnement
 Packaging

Verrines : Remplir les creux !

Collection «Esmeralda»



1410088N/C1



1410088TV



1410088B





40172T



40190T

SOUPIÈRE PS «RODÉO DRIVE» NOIRE
 «RODEO DRIVE» PS black soup bowl
 Sopera cóctel «RODEO DRIVE» PS negra

 88x63x52 mm
 1410088N/C1
 300





SOUPIÈRE «RODÉO DRIVE» PS TRANSPARENT VERT
 «RODEO DRIVE» PS transparent soup bowl
 Sopera cóctel «RODEO DRIVE» PS transparente

 88x63x52 mm
 1410088TV
 300



SOUPIÈRE PS «RODÉO DRIVE» BLANCHE
 «RODEO DRIVE» PS white soup bowl
 Sopera cóctel «RODEO DRIVE» PS blanca

 88x63x52 mm
 1410088B
 300





BOL «RIVIERA» PS TRANSPARENT VERT
 «RIVIERA» PS transparent green bowl
 Bol «RIVIERA» PS transparente verde

 75x35 mm
 40172T
 500 (10x50)



«SPHÈRE SCOOP» PS TRANSPARENTE + COUVERCLE
 «SCOOP» PS bowl + Lid
 Tazón «SCOOP» PS + Tapa

 Ø 90x69 mm
 40190T
 300 (6x50)



Verrines : Simple fond, double fond, il ne reste qu'à garnir !

Collection «O'Ronde»

MATIÈRE :
PS



8410012/C



8410012/C





8410013/C



8410015/C

VERRINE «ESFERA» 8 CL



«ESFERA» 8 CL

 8 cl
 8410012/C
 200 (10X20)



VERRINE «ESFERA» 12 CL



«ESFERA» 12 CL

 12 cl
 8410014/C
 200 (10X20)



VERRINE «ESFERA» 15 CL

«ESFERA» 15 CL

 15 cl
 8410013/C
 100 (10X10)



VERRINE «ESFERA» 20 CL

«ESFERA» 20 CL

 20 cl
 8410015/C
 100 (10X10)



Dimensions
Dimensions



Capacité
Capacity



Référence
Reference



Conditionnement
Packaging

Verrines Vision Verte

◇ *Pulp Instinct*

Laissez parler votre instinct! La pulpe est un matériau totalement naturel fait de fibres de cannes à sucre. Il est totalement biodégradable et compostable. Il passe aussi au micro-onde et résiste aux graisses. Vous voudriez plus? Don't forget : Pulp is beautiful !!! (n'oubliez pas : la pulpe est magnifique)

◆ *Wood Mood*

Esprit nature et ambiance bois, un matériau inimitable et indémodable ! entrez dans la ronde de l'élégance naturelle avec notre collection 100 % bois ! Pin, Peuplier, Bambou !

Découvrez les milles et unes facettes du bois !



Notre Vision Verte est ouverture, simplicité, praticité, respect, liberté, envie, futur, innovation, rapidité, beauté. Toujours positive et poétique, notre vision verte prêche l'envie d'un demain radieux, tout simplement. Alors, que vous soyez d'humeur bois, ou d'instinct pulpe, notre vision verte vous séduira ! Pour plus de solutions écologiques, n'hésitez pas à consulter notre catalogue «Vision Verte» ou le site www.vision-verte.com.

Verrines : Laissez parler votre instinct

Collection «Pulp Instinct»



1154010



1451078



1151105



11521105

VERRINE PULPE «FEUILLE»

«LEAF-SHAPED» cellulose verrine
Recipiente de pulpa prensada «HOJA»



105 x 51 x 29 mm
1154010
1000 (40x25)



VERRINE PULPE «1/2 OEUF»

«HALF-OVAL-SHAPED» cellulose verrine
Recipiente de pulpa prensada «SEMIOVALADO»



80 x 55 x 30 mm
1451078
1000 (40x25)



COUPE PULPE RONDE DIAM.105

Round cellulose dish
Plato pulpa redondo

Diam. 105 mm
11511105
1000 (40x25)



COUPE PULPE CARRÉE 110x110

Square cellulose dish
Plato pulpa cuadrado

110x110 mm
11521115
1000 (40x25)



MINI POT EN PULPY MINI 14 ML

Pulp pot 14 cl
Pulp pot 14 cl

14 CL/5 OZ
BIO826140
1000 (40x25)



Demandez
notre nouveau
catalogue Vision verte



Dimensions
Dimensions



Capacité
Capacity



Référence
Reference



Conditionnement
Packaging

Verrines : Partir à la dérive

Collection «Wood Mood»



BIO330070





BIO330170



BIO330110



Ambiance Pin

PETITE BARQUETTE PIN
Small pine serving boat
Cesta pequeña de pino

 70 mm
 BIO330070
 4000 (40x100)





MOYENNE BARQUETTE PIN
Medium pine serving boat
Cesta mediana de pino

 115x65 mm
 BIO330110
 4000 (40x100)



GRANDE BARQUETTE PIN
Large pine serving boat
Cesta grande de pino

 170x85x20 mm
 BIO330170
 2000 (20x100)



Pour compléter cette
gamme, retrouvez nos
couverts en bois p.133

Verrines : Une explosion de saveurs

Collection «Wood Mood»



1192006



3282554113778



1191206



3282554113768



1191006



1191012

Ambiance Bambou

COUPELLE CARRÉE BAMBOU Ø 60 MM

Small square bamboo dish
Fuente cuadrada bambú

60x60 mm
1192006
240 (10x24)



COUPELLE RONDE BAMBOU Ø 60 MM

Small round bamboo plate
Fuente redonda bambú

Ø 60 mm
1191006
240 (10x24)



COUPELLE RONDE CREUSE BAMBOU Ø 50 MM

Small round bamboo dish
Fuente redonda honda

Ø 50 mm
3282554113778
12



RAMEQUIN «DUO ROND» BAMBOU

Bamboo «DUO» ramekin
Ramequín «DOBLE» bambú

120x60 mm
1191012
120 (10x12)



COUPELLE CARRÉE INTÉRIEUR ROND BAMBOU 60x60 MM

Small square bamboo dish with round interior
Fuente cuadrada interior redondo bambú

60x60 mm
1191206
240 (10x24)



Demandez
notre catalogue
NOMADE



Verrines : Varier les plaisirs

Collection «Wood Mood»



1191018

1580170

1591309

1591310

1192018

Ambiance Bamboo

RAMEQUIN «TRIO ROND» BAMBOU

Round bamboo «TRIO» ramekin
Ramequín redondo «TRIPLE» bambú

180x60 mm
1191018
120 [10x12]



RAMEQUIN «TRIO CARRÉ» BAMBOU

Square bamboo «TRIO» ramekin
Ramequín cuadrado «TRIPLE» bambú

180x60 mm
1192018
240 [10x24]



CUILLÈRE «GOUTTE» BAMBOU

Bamboo «TEARDROP»
Cuchara «GOTA» bambú

90x36 mm
1591309
240 [10x24]



CUILLÈRE «PELLE» BAMBOU

Bamboo «SCOOP»
Cuchara «PALA» bambú

100x30 mm
1591310
240 [10x24]



PIQUES BAMBOU FOURCHETTE

PIKES BAMBOO FORK
CLAVIJAS BAMBÚ BANDA

90 mm
1580170
2000 [20X1000]



Verrines : De quoi présenter l'impossible

Collection «Wood Mood»



158105 158150 158180 1580070 1580105 1580180 158290 1582105 1582120 1583120 1584120

Ambiance Bambou

PIQUE DRAPEAU BAMBOU

FLAG PIQUE BAMBOO
PALILLO EXTREMO PLANO BAMBÚ

- 105 mm
 158105
 2000 (20 x 100)
- 150 mm
 158150
 2000 (20 x 100)
- 180 mm
 158180
 2000 (20 x 100)



DÉCOR COCKTAIL BOIS

DECO BOIS COCKTAIL
PALILLO CÓCTEL BAMBÚ

- 90 mm
 158290
 100
- 105 mm
 1582105
 100
- 120 mm
 1582120
 100



PIQUE NOEUD BAMBOU

PIQUE BAMBOO KNOT
PALILLO NUDO BAMBÚ

- 70 mm
 1580070
 2000 (20 x 100)
- 100 mm
 1580105
 2000 (20 x 100)
- 180 mm
 1580180
 2000 (20 x 100)



PIQUE BAMBOU BOULE

PIQUE BAMBOO LOOP
PIQUE BAMBÚ BUCLE

- BOULE COULEUR NATURELLE
 120 mm
 1584120
 100
- BOULE COLORIS ASSORTIS
 120 mm
 1583120
 100



Verrines : Piquez vos envies

Collection «Wood Mood»



WT108



WT106



WT100



WT104



WT102

PIQUE COCKTAIL 1 POINTE

1 TIP PICNIC COCKTAIL
1 PUNTA DE CÓCTEL DE PICNIC

80 mm
WT108
1000



PIQUE COCKTAIL DOUBLE POINTES

PIQUE COCKTAIL DOUBLE POINTES
COCTEL PIQUE DOBLE

68 mm
WT106
1000



BROCHETTE BOIS 150 MM

BROCHETTE WOOD 150 MM
MADERA BROCHETTE 150 MM

150 mm
WT100
200



BROCHETTE BOIS 200 MM

BROCHETTE WOOD 200 MM
MADERA BROCHETTE 200 MM

200 mm
WT104
200



BROCHETTE BOIS 300 MM

BROCHETTE WOOD 300 MM
MADERA BROCHETTE 300 MM

300 mm
WT102
200



Verrines : Piquez vos envies

Collection «Wood Mood»



1580140



1580110



158000/C



WT521

AGITATEUR CAFE BOIS 140 MM

Wooden coffee stirrer
Removedor para café madera



140x5 mm
1580140
10000 (10x1000)



CURE-DENTS BOIS ENVELOPPÉS INDIVIDUELLEMENT

Individually wrapped wooden toothpicks
Mondadientes envase individual



-
WT521
1000



AGITATEUR CAFE BOIS 110 MM

Wooden coffee stirrer
Removedor para café madera



110x5 mm
1580110
10000 (10x1000)



BAGUETTES CHINOISE BOIS ENVELOPPÉES

Wooden chopsticks in envelope
Palillos chinos madera



200 mm
158000/C
3000 (30x100)



Verrines Frenchy Folies

Verre

PS - PP

Faïence

Porcelaine



Verrines : Verres en verre avez-vous dit ?

Collection «Frenchy folies»

MATIÈRE :
VERRE



0026102852286



5410808840374



5410808860280



5410808101994



8693357035157



3356390079509



0026102849828

VERRINE VERRE «LUDICO» 6 CL

«LUDICO» verrine
Vasito «LUDICO»



6 cl
0026102852286
6



VERRINE VERRE «CLUB» 6 CL

«CLUB» verrine
Vasito «CLUB»



6 cl
5410808101994
6



VERRINE VERRE «DUKE» 5 CL

«DUKE» verrine
Vasito «DUKE»



5 cl
5410808840374
6



VERRINE VERRE «BOSTON» 7 CL

«BOSTON» verrine
Vasito «BOSTON»



7 cl
8693357035157
12



VERRINE VERRE «NORWAY» 7 CL

«NORWAY» verrine
Vasito «NORWAY»



7 cl
5410808860280
6



VERRINE VERRE «ALANYA» 10 CL

«ALANYA» verrine
Vasito «ALANYA»



10 cl
3356390079509
6



VERRINE VERRE «SHETLAND» 9 CL

«SHETLAND» verrine
Vaso «SHETLAND»



9 cl
0026102849828
12



Dimensions
Dimensions



Capacité
Capacity



Référence
Reference



Conditionnement
Packaging

Verrines : Petit et mignon

Collection «Frenchy folies»

MATIÈRE :
VERRE



84360037297 0026102492475 5410808830634 5410808102663





8004360037319 8004360037302 84360037296

3256390091280 5410808875208

VERRINE VERRE «CARAVELLE» DÉPOLIE 20 CL



«CARAVELLE» frosted verrine
Vasito esmerilado «CARAVELLE»

 20 cl
 84360037297
 6



VERRINE VERRE «CARAVELLE» 10 CL



«CARAVELLE» verrine
Vasito «CARAVELLE»

 10 cl
 8004360037319
 6



VERRINE VERRE «DISCO» 5 CL



«DISCO» Verrine
Vasito «DISCO»

 5 cl
 5410808830634
 6



VERRINE VERRE «CARAVELLE» 15,5 CL



«CARAVELLE» verrine
Vasito «CARAVELLE»

 15,5 cl
 8004360037302
 6



VERRINE VERRE «DISCO» 9 CL



«DISCO» Verrine
Vasito «DISCO»

 9 cl
 5410808102663
 6



VERRINE VERRE «CARAVELLE» 20 CL



«CARAVELLE» verrine
Vasito «CARAVELLE»

 20 cl
 84360037296
 6



VERRINE VERRE «BARIL» 16 CL



«BARIL» verrine
Vasito «BARIL»

 16 cl
 0026102492475
 6



VERRINE VERRE «FESTIVAL» 8 CL



«FESTIVAL» verrine
Vasito «FESTIVAL»

 8 cl
 3256390091280
 6



VERRINE VERRE «COSMOS» 5 CL

«COSMOS» verrine
Vasito «COSMOS»

 5 cl
 5410808875208
 6



Dimensions
Dimensions



Capacité
Capacity



Référence
Reference



Conditionnement
Packaging

Verrines : Un océan d'envie

Collection «Frenchy folies»

MATIÈRE :
VERRE



5410808103561



5410808103554



5410808103578



5400808102670



5400808103233



5410808102076



5410808103318



5410808103592

VERRE À SMOOTHIE «BARISTA» EN VERRE

«BARISTA» smoothie Glass
Vaso para smoothies»BARISTA»



12 cl
5410808103561
6



22 cl
5410808103554
6



37 cl
5410808103578
6



VERRINE VERRE «CARAT» 12 CL

«CARAT» verrine
Vasito «CARAT»



12 cl
5400808102670
6



VERRINE VERRE «CARAT» 21 CL

«CARAT» verrine
Vasito «CARAT»



21 cl
5400808103233
6



VERRINE VERRE «DISCO» 42 CL

«DISCO» Verrine
Vasito «DISCO» ancho «dish»



42 cl
5410808103592
4



VERRINE VERRE «ATOLL»

«ATOLL» Verrine
Vasito «ATOLL3»



11 cl
5410808102076
6



25 cl
5410808103318
6



Dimensions
Dimensions



Capacité
Capacity



Référence
Reference



Conditionnement
Packaging

Verrines : Une pyramide de créativité

Collection «Frenchy folies»

MATIÈRE :
VERRE



8411712016432



5410808103301



026102867846



3256390100043



8411712016456



000007539053



541080810486

VERRINE VERRE «BODEGA» 37 CL

«BODEGA» verrine
Vasito «BODEGA»



37 cl



8411712016432



12



VERRINE VERRE «BODEGA» 20 CL

«BODEGA» verrine
Vasito «BODEGA»



20 cl



8411712016456



12 [2x6]



VERRINE VERRE COUPE SANS PIED «HELSINKI» 25 CL

«HELSINKI» bowl verrine
Vasito copa «HELSINKI»



25 cl



5410808103301



6



VERRINE VERRE PYRAMIDE «VERTIGO» 3 NIVEAUX FERMÉE

«VERTIGO» pyramid verrine
Vasito en pirámide «VERTIGO»



37 cl / 22 cl / 12 cl



000007539053



1



VERRINE VERRE COUPE SANS PIED «COMETA» 25 CL

«HELSINKI» bowl verrine
Vasito copa «HELSINKI»



25 cl



026102867846



6



VERRINE VERRE PYRAMIDE «VERTIGO» 4 NIVEAUX FERMÉE

«VERTIGO» pyramid verrine
Vasito en pirámide «VERTIGO»



37 cl / 22 cl / 12 cl / 12 cl



541080810486



1



VERRE À TAPAS VERRE 20 CL

Tapas glass
Vaso para tapas



20 cl



3256390100043



12



Dimensions
Dimensions



Capacité
Capacity



Référence
Reference



Conditionnement
Packaging

Verrines : Incubateur d'idée

Collection «Frenchy folies»

MATIÈRE :
VERRE



99V11111



99V12111



99V11116



99V4104



99V21110



H53AO105P



99V3116



99V2114

MIGNONETTE TUBE À VIS VERRE 4 CL

Mini glass tube with screw cap
Minitubo de vidrio con tapón



4 cl



99V4104



96 (8x12)



PETIT BOCAL CARRÉ VERRE

JOINT BLANC 11 CL
Small square jar
pequeño cuadrado



11 cl



99V12111



96 (8x12)



MINI BOUTEILLE VERR

AVEC BOUCHON MÉCANIQUE 6,5 CL
Mini bottle with swing top
Minibotella con tapón



6,5 cl



99V3166



120 (10x12)



PETIT BOCAL ROND VERRE

JOINT BLANC 11 CL
Small round jar
Tarro pequeño redondo



11 cl



99V11111



96 (8x12)



POT À CONFITURE HAUT VERRE + COUVERCLE 10,6 CL

Jam jar
Tarro para mermelada



10,6 cl



99V21110



96 (8x12)



PETIT BOCAL VERRE HAUT JOINT BLANC 6,5 CL

Small jar with white rubber seal
Tarro pequeño con goma blanca



6,5 cl



99V11116



96 (8x12)



Compatible avec les joints de couleur

MINI POT À CONFITURE VERRE + COUVERCLE 4,5 CL

Mini jam jar
Minitarro para mermelada



4,5 cl



99V21114



96 (8x12)



POT À CONFITURE HEXAGONAL VERRE + COUVERCLE 10 CL

Hexagonal jam jar
Tarro hexagonal para mermelada



10,5 cl



H53AO105P



12



Dimensions
Dimensions



Capacité
Capacity



Référence
Reference



Conditionnement
Packaging

Verrines : Mariez les couleurs

Collection «Frenchy folies»



MATIÈRE :
VERRE



Avec ce produit choisissez votre code référence de joint couleur !

MINI BOCAL BAS VERRE TRANSPARENT 4,5 CL

Mini Jar 4.5 cl
Minitarro 4,5 cl

 4,5 cl
 99V1114
 96 [8x12]



Jouez avec les couleurs !



JOINT GRIS/ARGENT <i>white rubber seal / Goma blanca</i>	 3700466100692
JOINT ROUGE <i>Red rubber seal / Goma roja</i>	 3700466100807
JOINT ORANGE <i>Orange rubber seal / Goma blanca</i>	 3700466100777
JOINT ROSE <i>Pink rubber seal / Goma rosa</i>	 3700466100791
JOINT NOIR <i>Black rubber seal / Goma negra</i>	 3700466100753
JOINT CHOCOLAT <i>Chocolate Brown rubber seal / Goma marrón</i>	 3700466100739
JOINT VERT ANIS <i>--- rubber seal / Goma ---</i>	 3700466100814
JOINT BLEU CIEL <i>--- rubber seal / Goma ---</i>	 3700466100708
JOINT BLEU FONCE <i>--- rubber seal / Goma ---</i>	 3700466100715
JOINT TURQUOISE <i>--- rubber seal / Goma ---</i>	 3700466100722
JOINT FUSHIA <i>--- rubber seal / Goma ---</i>	 3700466100746
JOINT JAUNE <i>yellow rubber seal / Goma ---</i>	 3700466100760
JOINT PARME <i>--- rubber seal / Goma ---</i>	 3700466100784
JOINT VERT FLUO <i>--- rubber seal / Goma ---</i>	 3700466100821
JOINT VERT FONCE <i>--- rubber seal / Goma ---</i>	 3700466100838
JOINT VIOLET <i>--- rubber seal / Goma ---</i>	 3700466100845



12



Verrines : Tradition des formes

Collection «Frenchy folies»



8470125



8470350



8470300





8470450

MATIÈRE :
PET

MATIÈRE :
PS

BOCAL «TERROIR» PLASTIQUE 125 ml

«TERROIR» container
Bocal «TERROIR»

 125 ml
 8470125
 84



BOCAL «TERROIR» PLASTIQUE 300 ml



«TERROIR» container
Bocal «TERROIR»

 300 ml
 8470300
 60 (10x6)



BOCAL «TERROIR» PLASTIQUE 350 ml



«TERROIR» container
Bocal «TERROIR»

 350 ml
 8470350
 48



BOCAL «TERROIR» PLASTIQUE 450 ml

«TERROIR» container
Bocal «TERROIR»

 450 ml
 8470450
 60 (10x6)



Verrine réutilisable



Verrines : Modernité des matériaux

Collection «O'Ronde»

MATIÈRE :
PS



8470045



8470080





8470300



8470450

MINI BOCAL PS TRANSPARENT 4,5 CL / JOINT ORANGE



PS mini Jar 4.5 cl
Minitarro PS 4,5 cl

 H50/ø45 mm - 4,5 cl
 8470045
 240 (10x24)



MINI BOCAL PS TRANSPARENT 30 CL / JOINT ORANGE



PS mini Jar 30 cl
Minitarro PS 30 cl

 H50/ø100 mm - 30 cl
 8470300
 60 (10x6)



MINI BOCAL PS TRANSPARENT 8 CL / JOINT ORANGE



PS mini Jar 8 cl
Minitarro PS 8 cl

 H70/ø45 mm - 8 cl
 8470080
 240 (10x24)



BOCAL «TERROIR» PLASTIQUE 450 ml

«TERROIR» container
Bocal «TERROIR»

 450 ml
 8470450
 60 (10x6)



Transport facilité avec le plateau «BENTO» !

PLATEAU BENTO CARTON NOIR/RED RHODAMINE
(Réf. 1200320) Page 64



Verrines : Tradition du futur

NOUVEAU

Collection «Frenchy folies»

MATIÈRE :
PS



haut

profil

8470013



haut

profil

8470006



haut

profil

8470005

VERRINE YA'OURT EN PS 13 CL

Glass «yoghurt» 13 cl
Vaso «Yogur» 13 cl



L63xP63xH62 mm



8470013



200 (20x10)



VERRINE CONFIOTE EN PS 6 CL

Glass «yoghurt» 5 cl
Vaso «Yogur» 5 cl



6 CL



8470005



400 (20x20)



VERRINE P'TIT SUISSSE EN PS 6 CL

Glass «yoghurt» 6 cl
Vaso «Yogur» 6 cl



L48xP48xH54 mm



8470006



400 (20x20)

sur commande
to order / de encargo



COUVERCLE MINI CONFIOTE

Cover mini confiote
Cubierta mini confiote

9 couleurs (noir - blanc - chocolat - vert anis - ivoire -
turquoise - or - fushia - aubergine)



Ø46



8470005COV... (selon couleur)



400 (20x20)



Dimensions
Dimensions



Capacité
Capacity



Référence
Reference



Conditionnement
Packaging

Verrines : Envie de douceurs

NOUVEAU

Collection «Frenchy folies»

MATIÈRE :
PS



8430180



8430180COV



8430250



8430250COV

VERRE BODEGA PS INJECTÉ 180 CC
Glass bodega PS injected 180cc
Cristal bodega PS inyectado 180cc

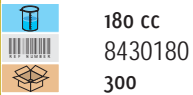

180 cc
8430180
300



COUVERCLE VERRE BODEGA 180 CC
glass lid bodega 180cc
tapa de vidrio 180cc bodega

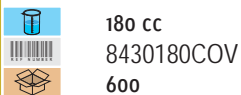

180 cc
8430180COV
600



VERRE BODEGA PS INJECTÉ 250 CC
Glass bodega PS injected 250cc
Cristal bodega PS inyectado 250cc



250 cc
8430250
300



COUVERCLE VERRE BODEGA 180 CC
glass lid bodega 180cc
tapa de vidrio 180cc bodega

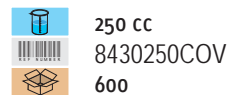

250 cc
8430250COV
600



Dimensions
Dimensions



Capacité
Capacity



Référence
Reference



Conditionnement
Packaging



Verrines : La tradition vient aussi d'ailleurs

Collection «Frenchy folies»

MATIÈRE :
PS

Le mini bol «MING» est une forme classique de la dynastie du même nom (1522 - 1566). Reposant sur un petit pied, il est recouvert d'une belle glaçure colorée.





846007



846007COV



MINI BOL «MING» PS BICOLORE
«MING» PS two-colour mini bowl
Minibol «MING» PS bicolor

 H25/ø45 mm
 846007
 200 [8x25]



COUVERCLE PS «MING»

Lid «MING» PS
Tapa «MING» PS

 -
 846007COV
 500



Variez les plaisirs avec nos couleurs festives !!!



846007A





846007A



846007A



MINI BOL «MING» PS BICOLORE COLORIS ASSORTIS (BLEU, ROSE, VERT INTÉRIEUR BLANC) 3 CL
«MING» PS mini Bowl in several colours [blue, pink and green with white interior]
Minibol «MING» PS bicolor

 Diam. 50 mm
 846007A
 225 [3x3x25]



COUVERCLE PS «MING»

Lid «MING» PS
Tapa «MING» PS

 -
 846007COV
 500



Dimensions
Dimensions



Capacité
Capacity



Référence
Reference



Conditionnement
Packaging

Verrines : Se mettre en boîte

NOUVEAU

Collection «Frenchy folies»

MATIÈRE :
PP



322106B



322106N

© 2015 MAHLE LEUCO

MINI BOÎTE SARDINE EN PP 6 CL

Mini sardine box 6 cl
Lata de sardinas Mini 6 cl
Coloris NOIR -BLANC

sur commande
to order / de encargo



L51xL105xH23 mm
322106N (NOIR)
200



L51xL105xH23 mm
322106B (BLANC)
200

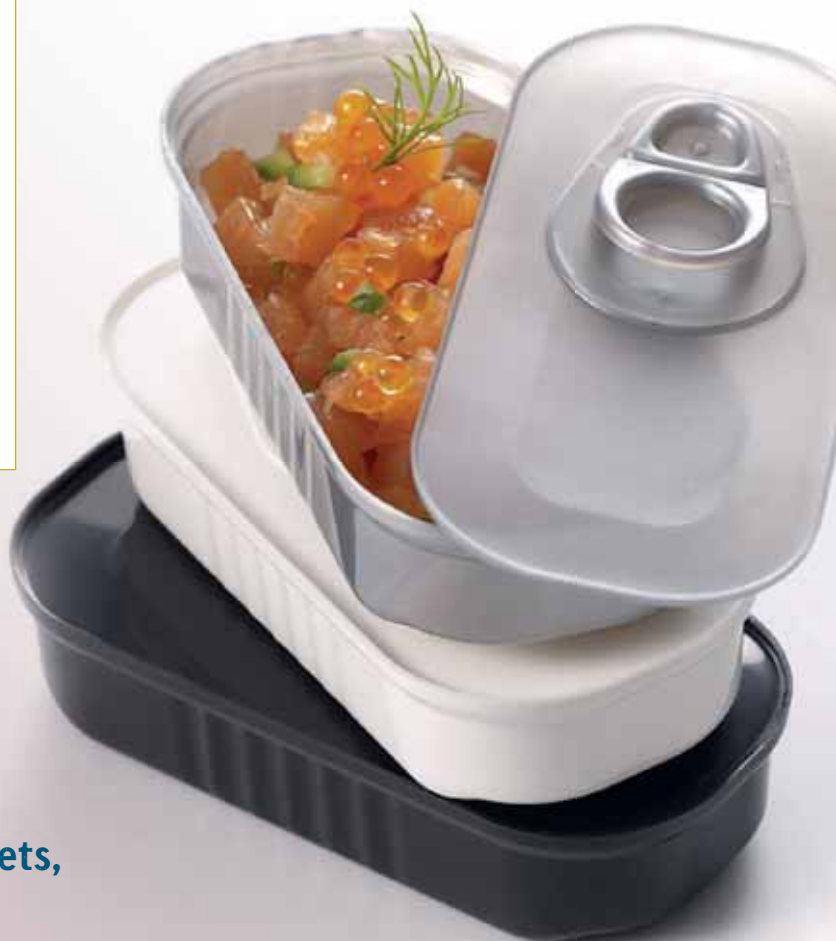

Pour la mise en valeur de vos mets,
utilisez des verrines originales !



Verrines : Tradition, modernité, à vous choisir...

Collection «Frenchy folies»



MATIÈRE :
PP



40270N



4020080N



4020300N

«MINI COCOTTE» OVALE PP NOIRE + COUVERCLE 8 CL

PP black Oval «MINI CASSEROLE» + Lid
«CAZUELITA» PP ovalada negra + tapa



L7x16,3xH3 cm - 8 cl

40270N

180 [30x6]



«MINI COCOTTE» RONDE PP NOIRE + COUVERCLE 8 CL

PP black Round «MINI CASSEROLE» + Lid
«CAZUELITA» PP redonda negra + tapa



8 cl

4020080N

200



«COCOTTE» RONDE PP NOIRE + COUVERCLE 30 CL

PP black Round «CASSEROLE» + Lid
«CAZUELITA» PP redonda negra + tapa



30 cl

4020300N

100



Pour compléter la gamme,
nous vous proposons :



FOURCHETTE COCKTAIL ARGENT
(Réf. 1513104) Page 126

CUILLERE COCKTAIL ARGENT
(Réf. 1543104) Page 126



FOURCHETTE COCKTAIL TRANSPARENTE
(Réf. 1513103) Page 126

CUILLÈRE COCKTAIL TRANSPARENTE
(Réf. 1543103) Page 126



CAISSE TRAITEUR KRAFT (Réf. 350338KB) Page 135



Dimensions
Dimensions



Capacité
Capacity



Référence
Reference



Conditionnement
Packaging

Verrines : Souvenirs, souvenirs...

Collection «Frenchy folies»



MATIÈRE :
FAÏENCE



3256390120516



3256390120486



3256390120485

«MINI-COCOTTE» RONDE FAÏENCE ROUGE 20 CL

Red round «MINI CASSEROLE»
«TARTERITA» roja de cerámica



50x100 mm [20 cl]

3256390120516

6



«MINI-COCOTTE» OVALE FAÏENCE ROUGE 25 CL

Red Oval «MINI CASSEROLE»
«TARTERITA» roja de cerámica



50x130 mm [25 cl]

3256390120486

6



«MINI-COCOTTE» OVALE FAÏENCE NOIRE 25 CL

Black Oval «MINI CASSEROLE»
«TARTERITA» negra de cerámica



50x130 mm [25 cl]

3256390120485

6



Également disponible en orange



Découvrez nos faitouts en PP ! page 39



Verrines : De toutes les matières, c'est le white qu'elle préfère.

Collection «Frenchy folies»



MATIÈRE :
PORCELAINE



0026102935910



0026102935934



0026102936177





0026102936153



0026102936054

COUPELLE CREUSE CARRÉE PORCELAINE 10 CL



Small square porcelain dish
Bol cuadrado

 55x85 mm (10 cl)
 0026102935910
 6



COUPE «SPIRIT» PORCELAINE 12 CL



«SPIRIT» porcelain bowl
Bol «SPIRIT»

 40x102 mm (12 cl)
 0026102936177
 6



CUILLERE CHINOISE PORCELAINE



Porcelain chinese spoon
Cuchara china

 15x60 mm
 0026102936054
 6



COUPE «LUDICO» PORCELAINE

«LUDICO» porcelain bowl
Bol «LUDICO»

 50x95 mm
 0026102936153
 6



Dimensions
Dimensions



Capacité
Capacity



Référence
Reference



Conditionnement
Packaging

Présentation

Présentoir plastique
Plateaux or & argent
Plateaux pour transport verrines



Présentation : Associez les couleurs



0915009



0915010



0915011



0915012

PRÉSENTOIR PLASTIQUE «OBÉLISQUE» ORANGE 4 NIVEAUX

«OBÉLISQUE» display stand with 4 round tiers
Expositor «OBÉLISQUE» con bandejas redonda



Ø 390xH620 mm

0915009

1

Niveaux :

Ø 390 mm

Ø 310 mm

Ø 250 mm

Ø 190 mm



PRÉSENTOIR PLASTIQUE «ARROW» ORANGE 4 NIVEAUX

«ARROW» display stand with 4 square tiers
Expositor «ARROW» con bandejas rectangulares



Ø 540x470xH630 mm

0915010

1

Niveaux :

470x340 mm

370x250 mm

250x170 mm

230x130 mm

sur commande
to order / de encargo



PRÉSENTOIR PLASTIQUE «GIZEH» VERT 4 NIVEAUX

«GIZEH» display stand with 4 tiers
Expositor «GIZEH» con bandejas circulares



Ø 560xH620 mm

0915012

1

Niveaux :

Ø 560 mm

Ø 460 mm

Ø 330 mm

Ø 220 mm

sur commande
to order / de encargo



PRÉSENTOIR PLASTIQUE «SQUALE» ROUGE 4 NIVEAUX

«SQUALE» display stand with 4 tiers
Expositor «SQUALE» con bandejas redondas



Ø 600x500xH600 mm

0915011

1

Niveaux :

600x430 mm

490x350 mm

270x370 mm

250x180 mm

sur commande
to order / de encargo



Dimensions
Dimensions



Capacité
Capacity



Référence
Reference



Conditionnement
Packaging

Présentation : Prenez de la hauteur



0915316

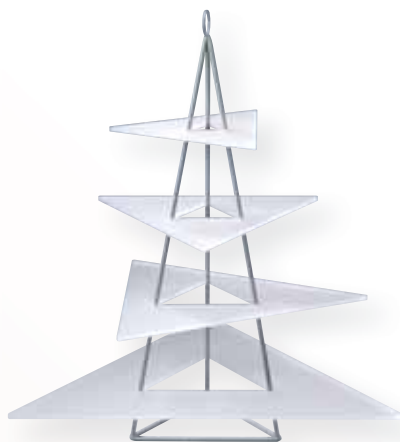

0915312



0915013

PRÉSENTOIR PLASTIQUE «PISA» 5 NIVEAUX

«PISA» display stand, 5 Tiers
Expositor «PISA»



H545 mm
0915316
1

5 niveaux 330x330 mm



PRÉSENTOIR PLASTIQUE «YING YANG» BLANC GIVRÉ 4 NIV.

«YING YANG» display stand with 4 tiers
Expositor «YING YANG»



400x270 mm
0915013
1

Niveaux :
290 mm
210 mm
130 mm
50 mm



PRÉSENTOIR PLASTIQUE «KÉPHREN» 4 NIVEAUX

«KEPHREN» display stand with 4 Tiers
Expositor «KEPHREN»



H720 mm
0915312
1

Niveaux :
650x570 mm
420x480 mm
340x390 mm
250x290 mm



0915005



Présentation : Empilez vos idées

0915029COV

0915021COV



0915029

0915021

8420004PRES

8420004

PLATEAU «LUXE» PS VERT TRANSPARENT

«LUXE» PS Transparent green tray
Bandeja «LUXE» PS transparente verde

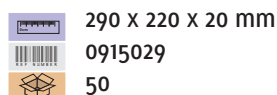

290 x 220 x 20 mm

0915029

50



COUVERCLE PET VERT TRANSPARENT

PET transparent green cover
Tapa PET transparente

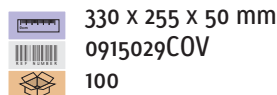

330 x 255 x 50 mm

0915029COV

100

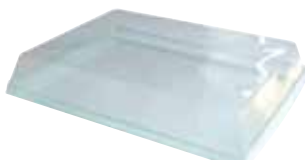

VERRINE «CÔNE» PS TRANSPARENTE

PS Transparent Verrine
Vasito PS transparente



4 cl

8420004

480 [4X120]



PRÉSENTOIR PLASTIQUE 12 VERRINES [5 PRÉSENTOIRS + 60 VERRINES]

Display Tray 12 Verrines [5 DISPLAY + 60 LOCKS]
Expositor 12 vasitos [5 + 60 VERRINES pantalla]



240x245x59 mm

8420004PRES

1



PLATEAU PS POUR 12 VERRINES

PS tray for 12 verrines
Bandeja PS para 12 vasitos



mm

0915021

25



COUVERCLE PS POUR PLATEAU POUR 12 VERRINES

PS cover for Tray for 12 verrines
Tapa PS para bandeja de 12 vasitos



mm

0915021COV

25



EMPILABLE

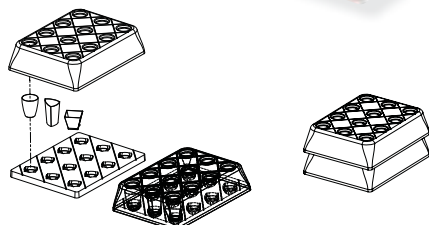

PRÉSENTOIR PLASTIQUE «CRISTAL» 12 VERRINES

'CRISTAL' Display Tray 12 Verrines
Expositor Cristal 12 vasitos

sur commande
to order / de encargo



215x300x39 mm

0915005

2



Présentation : L'or des Incas



9823120



9823123/C



9823124/C



9823125/C

MINI PLAT PET OR OCTOGONAL

PET gold octagonal mini serving tray
Fuentecita octogonal dorada



Ø 85 mm
9823120
1000 (8x125)



PLAT PET OR OCTOGONAL

Gold octagonal serving tray
Fuente octogonal dorada



255x385 mm
9823123/C
25



PLAT PET OR OCTOGONAL

PET gold octagonal serving tray
Fuente octogonal dorada



300x300 mm
9823124/C
50

sur commande
to order / de encargo



PLAT PET OR OCTOGONAL

PET gold octagonal serving tray
Fuente octogonal dorada



467x311 mm
9823125/C
25



Présentation : Le Rio de la Plata



9821112/C 9821114



9821113 9821115/C



9824116/C

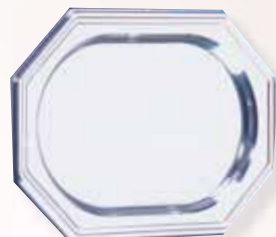

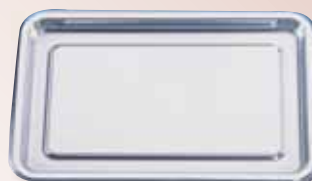

9823113/C



9827111/C



PLAT PET «CLASSIQUE»

PET «CLASSIC» Serving Tray
Fuente PET «CLASSIC»

 Ø 340 mm
 9821113
 50



sur commande
to order / de encargo



 Ø 460 mm
 9821115/C
 50



sur commande
to order / de encargo

PLAT PET «EUROPA»

PET «EUROPA» silver serving tray
Fuente PET plateada «EUROPA»



 Ø 310 mm
 9821112/C
 25



sur commande
to order / de encargo

PLAT PET «EUROPA»

PET «EUROPA» silver serving tray
Fuente PET plateada «EUROPA»

 Ø 400 mm
 9821114
 50



sur commande
to order / de encargo

PLAT PET OCTOGONAL ARGENT

PET octogonal silver serving tray
Fuente PET octogonal plateada



 255x385 mm
 9823113/C
 25



sur commande
to order / de encargo

COUVERCLE PET PLATS «EUROPA»

PET Cover for «EUROPA» Silver Serving Tray
Tapa PET para fuentes «EUROPA»

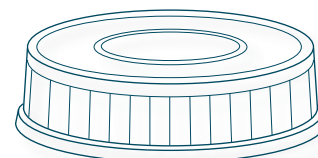

 Ø 400 mm
 9653516
 50



sur commande
to order / de encargo

PLAT PET OVAL ARGENT



PET silver oval serving tray
Fuente PET ovalada plateada

 291 x 454 mm
 9824116/C
 25



PLAT PET RECTANGULAIRE

PET rectangular serving tray
Fuente PET rectangular

 460x300 mm
 9827111/C
 50



sur commande
to order / de encargo



Dimensions
Dimensions



Capacité
Capacity



Référence
Reference



Conditionnement
Packaging

Présentation : La force du minéral



3700022455129



1135820



1132830



1135811



1135824



9823143/C

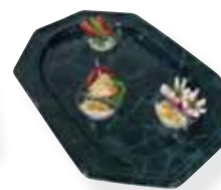



9823144/C

Tradition, Modernité, choisissez votre matière !

ASSIETTE COCKTAIL PS GRIS ARDOISE 20 x 20



Square grey PS slate tray
Plato cóctel PS gris pizarra

 200 x 200 x 16 mm
 1135820
 100 [10x10]



ASSIETTE COCKTAIL PS GRIS ARDOISE 30 x 14

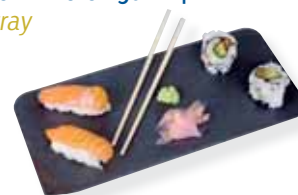

Rectangular grey PS slate tray
Plato cóctel PS gris pizarra

 300 x 140 x 17 mm
 1132830
 80 [8x10]





PLAT PET MARBRÉ NOIR OCTOGONAL

PET octagonal marbled black serving tray
Fuente PET octogonal jaspeada negra

 385x255 mm
 9823143/C
 25





 467x311 mm
 9823144/C
 25



sur commande
to order / de encargo

ASSIETTE COCKTAIL PS GRIS ARDOISE 11 x 11



Square grey PS slate tray
Plato cóctel PS gris pizarra

 110 x 110 x 11 mm
 1135811
 320 [8x40]



ASSIETTE COCKTAIL PS GRIS ARDOISE 24 x 24

Square grey PS slate tray
Plato cóctel PS gris pizarra

 240 x 240 x 17 mm
 1135824
 80 [8x10]





Non-Stop

Plateaux repas

Non Stop, c'est une gamme de plateaux repas modulables ou clefs en mains, pour répondre à vos attentes et à vos caprices... C'est tout et c'est bien!

Nos solutions COMBO permettent en utilisant une même base de garnir un plateau en fonction de vos envies ou de celles de vos clients. Idéal pour les traiteurs, il est évolutif et modulable. Nos plateaux COMBO permettent un grand choix de solution transport et présentation pour un, pour deux et toujours avec classe.

Avec nos plateaux SOLO, découvrez toute la facilité d'un plateau prêt à l'emploi. Toujours pratique, pensé pour vous, vous trouverez toujours un plateau pour une utilisation. Design, avec ou sans ravers, un, deux, jusqu'à 6 compartiments si vous le souhaitez. Vous trouverez autant de plateaux SOLO que vous avez de besoins.



Combo

Marco Polo
Famous Break
Bento
LUXE SOFT

Vision Verte - petit format
Vision Verte - grand format
Plateau étui kraft :
+ gamme thermoformé

Solo

6 compartiments
Le Vague
Le Cube
Plateau Ookī
Plateau Chisaï
Saladier wan
Plat Osara
Pause Déjeuner
Plateau Tokudaï
Plateau Prestige
Plateau Plat du Jour

+ gamme injecté
Gamme Bio Pulpe
Etui Kraft Vaisselle Bio
Plateau « Luxe Bois »
Plateau « Must » avec tirroir
Plateau « Must » sans tirroir
sans tirroir
Le Scellable
Le Standard
Le Baquette
Lunch Box

Plateaux repas - Combo

Le «MARCO POLO»

Le Marco Polo, à la découverte du bon goût
1 plateau, 4 possibilités pour le garnir !

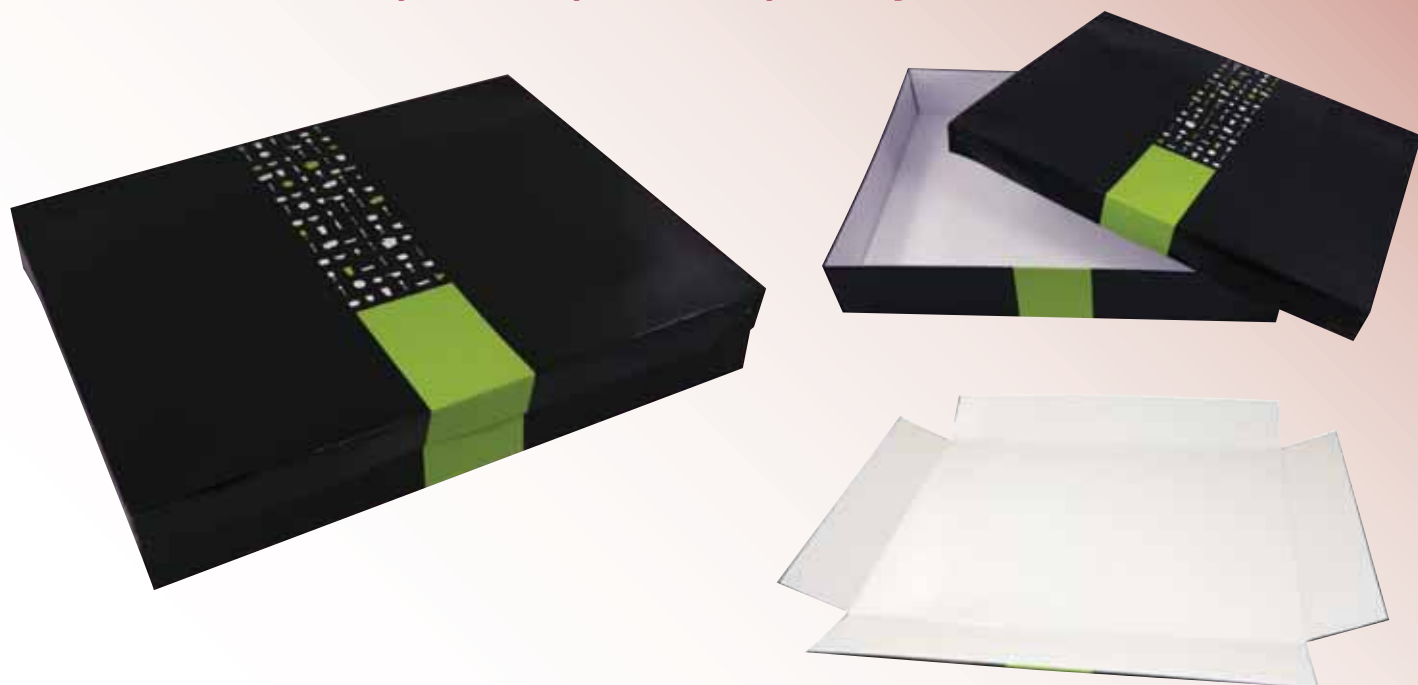

Un must sans bords !

Bords aimantés

PLATEAU MARCO POLO AVEC COUVERCLE

«MARCO POLO» TRAY BOX
BANDEJA «MARCO POLO»



40X30+6,5
1204030
50

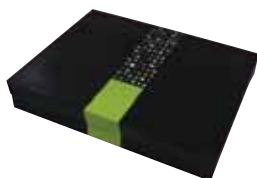

Le plateau «Marco Polo» est conçu pour vous, seul ou à deux tous les plaisirs sont permis.

Il est fonctionnel grâce :

- à sa base aimantée pouvant s'ouvrir et se déplier entièrement à plat.
- à son système de fermeture avec rabats des côtés et insertion du couvercle.



Dimensions
Dimensions



Capacité
Capacity



Référence
Reference



Conditionnement
Packaging

Plateaux repas - Combo

« MARCO POLO »

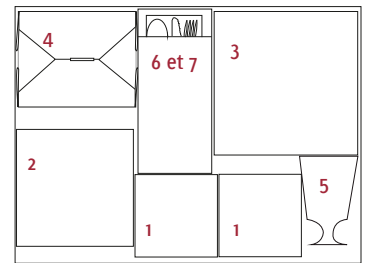

1 personne

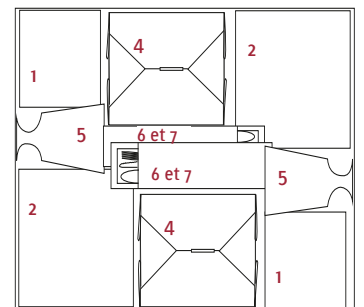

2 personnes

COMPOSITION : «ESMERALDA»

1 - ASSIETTE PS INJECTÉ VERT TRANSPARENT 90 x 90
+ COUVERCLE TRANSPARENT PET

90 x 90 x 20 mm
 11315009 + 11315009COV
 200

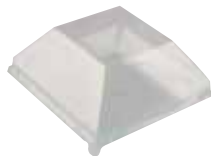

X2

4 - BOITE «FIRPACK» CARTON KRAFT BLANC

650 ml
 1330110/C
 500



X2

2 - ASSIETTE PS INJECTÉ VERT TRANSPARENT 130 x 130
+ COUVERCLE TRANSPARENT PET

130 x 130 x 20 mm
 11315013 + 11315013COV
 200

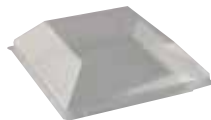

X2

5 - VERRE À VIN PS TRANSPARENT

17 cl
 GK20
 250 (10x25)



X2

3 - ASSIETTE «JADE» PS TRANSPARENT VERT
+ COUVERCLE TRANSPARENT PET

160x160 mm
 11315016 + 11315016COV
 200

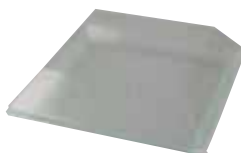

X2

6 - ETUI COUVERT BRUN «BON APPÉTIT»
+ SERVIETTE PASTEL 2 PLIS

200x85 mm
 0900302
 600

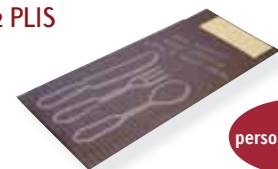

personnalisable

7 - FOURCHETTE + COUTEAU + CUIILLÈRE
TRANSPARENT «GIVRÉE» PS

180 mm
 1513318/1523319/1533318
 250 (10x25)



Plateaux repas - Combo

« MARCO POLO »

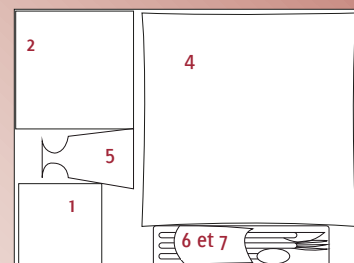

COMPOSITION : «VAGUE»

1 personne

1 - ASSIETTE PS INJECTÉ VERT TRANSPARENT 90 x 90 + COUVERCLE TRANSPARENT PET

90 x 90 x 20 mm
 11315009 + 11315009COV
 200

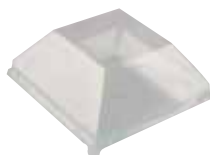

2 - ASSIETTE PS INJECTÉ VERT TRANSPARENT 130 x 130 + COUVERCLE TRANSPARENT PET

130 x 130 x 20 mm
 11315013 + 11315013COV
 200

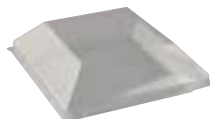

3 - ASSIETTE «VAGUE» NOIRE 24,5x24,5 CM

245x245 mm
 1131009
 300 (3x100)



4 - COUVERCLE PET TRANSPARENT «VAGUE» 24,5x24,5 CM

245x245 mm
 1131008
 300 (3x100)



5 - VERRE À VIN PS TRANSPARENT

17 cl
 GK20
 250 (10x25)



6 - ETUI COUVERT BRUN «BON APPÉTIT» + SERVIETTE PASTEL 2 PLIS

200x85 mm
 0900302
 600

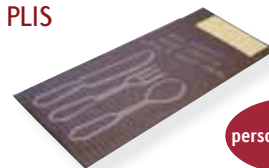

7 - FOURCHETTE + COUTEAU + CUILLÈRE TRANSPARENTE «GIVRÉE» PS

180 mm
 1513318/1523319/1533318
 250 (10x25)



8 - KIT 4/1 INOX RÉUTILISABLE (FOURCHETTE + COUTEAU + CUILLÈRE + SERVIETTE)

-
 0093119
 100



Plateaux repas - Combo

« MARCO POLO »

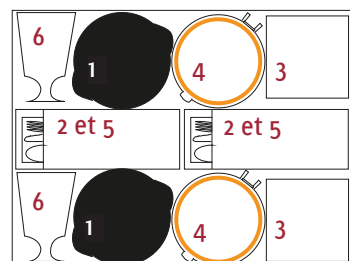

COMPOSITION : FRENCHY

2 personnes

1 - COCOTTE RONDE NOIRE PP 300 ML + COUVERCLE

X2

112 x 112 x 60 mm
4020300N
 100



4 - MINI BOCAL «TERROIR» PLASTIQUE 300 ML joint orange

X2

105 x 105 x 65 mm
8470300
 60 (10x6)



2 - FOURCHETTE + COUTEAU + CUIILLÈRE TRANSPARENTE «GIVRÉE» PS

X2

180 mm
1513318/1523319/1533318
 250 (10x25)



5 - ETUI COUVERT BRUN «BON APPÉTIT» + SERVIETTE PASTEL 2 PLIS

X2

200x85 mm
0900302
 600

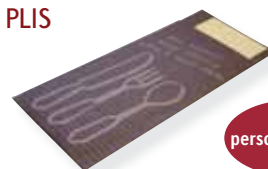

personnalisable

3 - BOITE «FIRPACK» CARTON KRAFT BLANC

X2

650 ml
1330110/C
 500



6 - VERRE À VIN PS TRANSPARENT

X2

17 cl
GK20
 250



Plateaux repas - Combo

Le « FAMOUS BREAK »

1 personne



1 fenêtre 1 calage
le top du transport

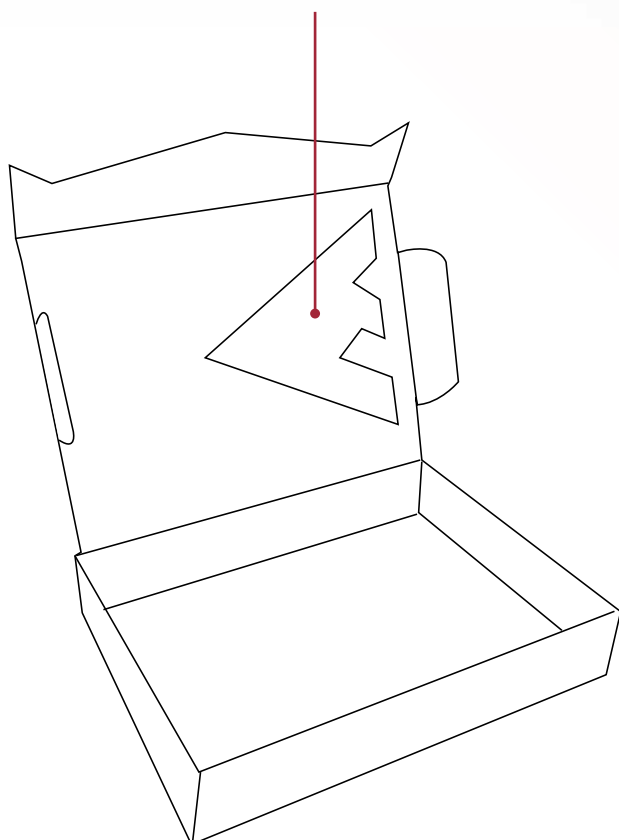

Fenêtre de visibilité
pour mettre en avant
vos produits.



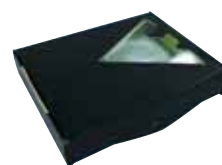

PLATEAU COFFRET «FAMOUS BREAK» CARTON NOIR/VERT
«FAMOUS BREAK» tray box in black and green cardboard
Caja con bandeja «FAMOUS BREAK» cartón negro/verde

 367 x 285 x 70 mm
 1201367
 50



Calage plateau repas
Rigging tray meals
Aparejo bandejas de comida

 282 x 355 x 26 mm
 1201367CAL
 50



Dimensions
Dimensions



Capacité
Capacity



Référence
Reference



Conditionnement
Packaging

Plateaux repas - Combo

« FAMOUS BREAK »

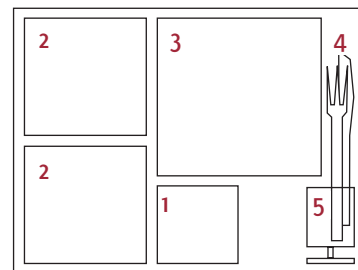

COMPOSITION : ESMERALDA FEVER

1 personne

1 - ASSIETTE «JADE» PS TRANSPARENT VERT

«JADE» PS transparent green plate
Plato PS verde transparente



1 - COUVERCLE «JADE» PS TRANSPARENT VERT

«JADE» PS transparent green lid
Tapa «JADE» PS verde transparente

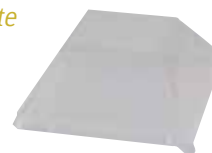
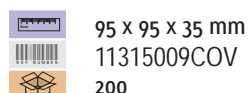

2 - ASSIETTE «JADE» PS TRANSPARENT VERT

'JADE' Transparent Green Plate
Plato PS verde transparente

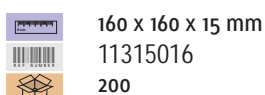

X2

2 - ASSIETTE «JADE» PS TRANSPARENT VERT

'JADE' Transparent Green Lid
Tapa PS verde transparente

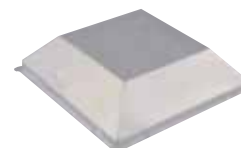
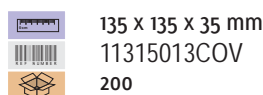

X2

3 - ASSIETTE «JADE» PS TRANSPARENT VERT

'JADE' Transparent Green Plate
Plato PS verde transparente

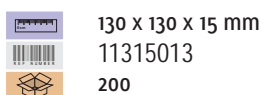

3 - ASSIETTE «JADE» PS TRANSPARENT VERT

'JADE' Transparent Green Lid
Tapa PS verde transparente

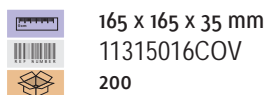

4 - SACHET COUVERTS PS TRANSPARENT 6/1

[Couteau, Fourchette, Cuillère, Serviette, sel et poivre
6-in-1 PS pack of transparent cutlery
[fork + knife + spoon + serviette + salt & pepper]
Bolsita cubiertos transparentes PS 6/1
[Cuchillo, tenedor, cuchara, servilleta, sal y pimienta]



5 - VERRE À PIED PS TRANSPARENT

PS transparent stemmed wine glass
Copa PS transparente



Plateaux repas - Combo

« FAMOUS BREAK »

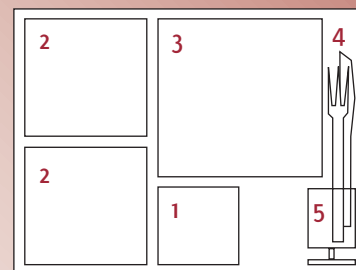

COMPOSITION : LE SOLO WHITE

1 personne

1 - RAVIER BLANC EN PS + COUVERCLE TRANSPARENT APET
WHITE RIBBON IN PS + COVER TRANSPARENT APET
BLANCO BOWL + TAPA TRANSPARENTE PS APET

135 x 135 x 20 mm
 1131014B
 200



4 - VERRE À PIED PS TRANSPARENT
PS transparent stemmed wine glass
Copa PS transparente

17 cl
 GK20
 250 (25x10)



2 - RAVIER BLANC EN PS + COUVERCLE TRANSPARENT APET
WHITE RIBBON IN PS + COVER TRANSPARENT APET
BLANCO BOWL + TAPA TRANSPARENTE PS APET **X2**

170 x 170 x 20 mm
 1131012B
 200



5 - SACHET COUVERTS PS TRANSPARENT 6/1
 (COUTEAU, FOURCHETTE, CUIILLÈRE, SERVIETTE, SEL ET POIVRE)
6-in-1 PS pack of transparent cutlery

180 mm
 1500661
 250



3 - RAVIER BLANC EN PS + COUVERCLE TRANSPARENT APET
WHITE RIBBON IN PS + COVER TRANSPARENT APET
BLANCO BOWL + TAPA TRANSPARENTE PS APET

100 x 100 x 20 mm
 1131013B
 200



Plateaux repas - Combo

« FAMOUS BREAK »

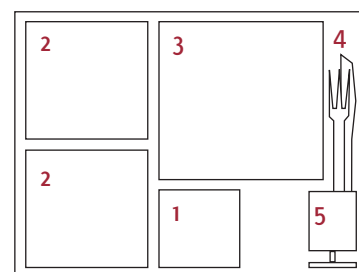

La Gamme «Vision verte» fabriquée à partir de pulpe de canne à sucre est idéale pour la vente à emporter. Ces contenants offrent de nombreux atouts : résistance et étanchéité aux sauces et aux graisses, micro-ondables jusqu'à 220 °C.



COMPOSITION : PULP'N KRAFT

1 personne

1 - Ravier pulpe blanc

Ravier white pulp
Ravier pulpa blanca

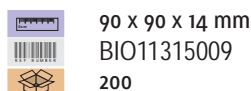

1 - Couvercle pour ravier pulpe blanc en APET

Cover for ravier white pulp
cobertura de la pulpa blanca ravier

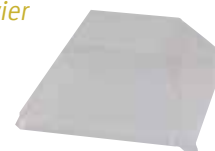
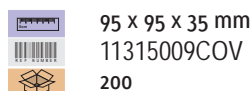

2 - Ravier pulpe blanc

Ravier white pulp
Ravier pulpa blanca

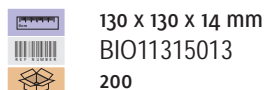

X2

2 - Couvercle pour ravier pulpe blanc en APET

Cover for ravier white pulp
cobertura de la pulpa blanca ravier

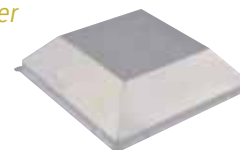
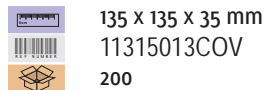

X2

3 - Ravier pulpe blanc

Ravier white pulp
Ravier pulpa blanca

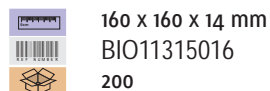

3 - Couvercle pour ravier pulpe blanc en APET

Cover for ravier white pulp
cobertura de la pulpa blanca ravier

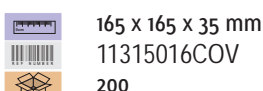

4 - Sachet souverts luxe 4 en 1 biodégradable

Luxury bag covered 4 in 1 biodegradable
Bolsa de lujo cubierto 4 en 1 biodegradables

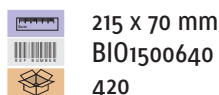

5 - Gobelet PLA transparent 20cl en APET

PLA transparent cup 20cl
PLA taza transparente 20cl

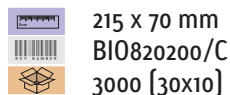

Plateaux repas - Combo

Le « BENTO »

TRANSPORT DE VERRINES



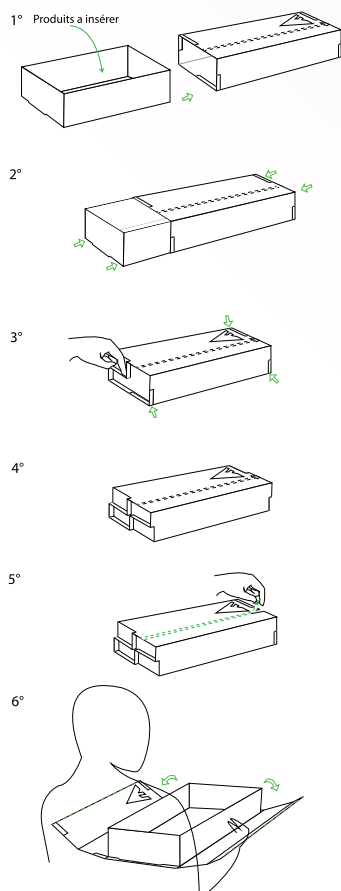
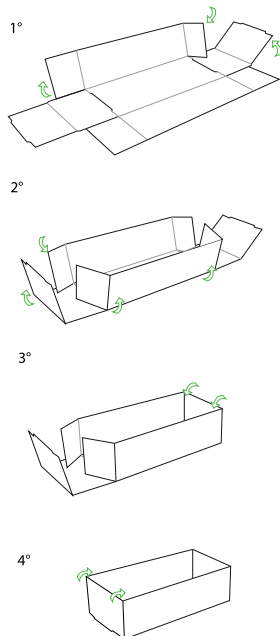

Scénario d'usage de la cale et du plateau :

Scénario d'usage de la cale:



Le plateau «Bento» vous offre la possibilité de transporter votre repas ou vos verrines. Il allie la fonctionnalité d'un set de table et une esthétique originale.

PLATEAU «BENTO»
 CARTON NOIR/RED RHODAMINE
 + CALE (300x140x90mm)
 Black and pink «BENTO»
 cardboard tray
 Bandeja «BENTO»
 cartón negro/rosa+soporte

 320 x 140 x 90 mm
 1200320
 100



Dimensions
Dimensions



Capacité
Capacity



Référence
Reference



Conditionnement
Packaging

Plateaux repas - Combo

Le « BENTO »

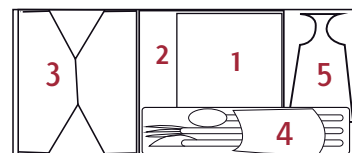

La Gamme «JADE» est idéale pour les traiteurs et restaurateurs qui veulent présenter leurs préparations dans des contenants élégants, modernes et solides. Le coloris vert transparent permet d'ajouter une touche brillante et raffinée.

COMPOSITION : EMERALDA

1 personne

1 - ASSIETTE PS INJECTÉ VERT TRANSPARENT 90 x 90

*PS transparent green plate
Plato PS verde transparente*

90 x 90 x 20 mm
 11315009
 200



1 - COUVERCLE PET TRANSPARENT

*Transparent PET lid
Tapa PET transparente*

95 x 95 x 40 mm
 11315009COV
 200

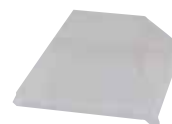

2 - ASSIETTE PS INJECTÉ VERT TRANSPARENT 130 x 130

*Transparent PS green plate
Plato PS verde transparente*

130 x 130 x 20 mm
 11315013
 200



2 - COUVERCLE PET TRANSPARENT

*Transparent PET lid
Tapa PET transparente*

140 x 140 x 40 mm
 11315013COV
 200

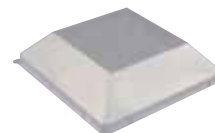

3 - BOITE «FIRPACK» CARTON KRAFT BLANC

*«FIRPACK» box in white cardboard
Caja «FIRPACK» de cartón blanca*

650 ml
 1330110
 450



4 - SACHET COUVERTS PS TRANSPARENT 6/1

*[Couteau, Fourchette, Cuillère, Serviette, sel et poivre
6-in-1 PS pack of transparent cutlery
(fork + knife + spoon + serviette + salt & pepper)
Bolsita cubiertos transparentes PS 6/1
(Cuchillo, tenedor, cuchara, servilleta, sal y pimienta)]*

180 mm
 1500661
 250



5 - VERRE À VIN PS TRANSPARENT

*PS transparent stemmed wine glass
Copa PS transparente*

17 cl
 GK20
 250



Plateaux repas - Combo

Le « BENTO »



COMPOSITION : FRENCHY

1 personne

1 - SACHET COUVERTS PS TRANSPARENT 6/1
 [Couteau, Fourchette, Cuillère, Serviette, sel et poivre
6-in-1 pack of transparent cutlery
(fork + knife + spoon + serviette + salt & pepper)
 Bolsita cubiertos transparentes ps 6 en 1
(Cuchillo, tenedor, cuchara, servilleta, sal y pimienta)

180 mm
 1500661
 250



3 - COCOTTE RONDE NOIRE PP 300 ML + COUVERCLE
Round black casserole + lid
 Cazuelita redonda negra + tapa

112 x 112 x 60 mm
 4020300N
 100



2 - MINI BOCAL «TERROIR» PLASTIQUE 300 ML
 joint orange

«TERROIR» mini-jar in plastic
 Minitarro «TERROIR» plástico

105 x 105 x 65 mm
 8470300
 60 [10x6]



4 - VERRE «CRISTAL» PS OCTOGONAL 25 cl
«CRISTAL» octagonal glass
 Vaso «CRISTAL» octogonal

25 cl
 7023/C
 600 [20x30]



Dimensions
 Dimensions



Capacité
 Capacity



Référence
 Reference



Conditionnement
 Packaging

Plateaux repas - Combo

Le « BENTO »



COMPOSITION : VERRINE

1 - MINI BOCAL «TERROIR» PLASTIQUE 6,5cl
joint orange

X15

«TERROIR» mini-jar in plastic
Minitarro «TERROIR» plástico



6,5 cl
99V1166
96 [8x12]

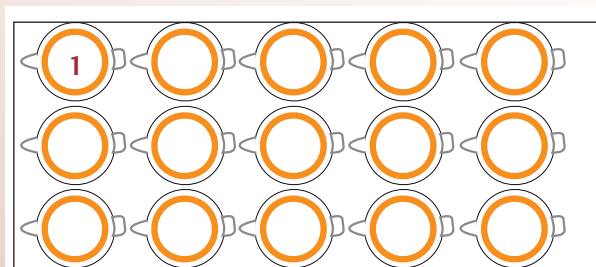

Plateaux repas - Combo

le «Kraft'n go»

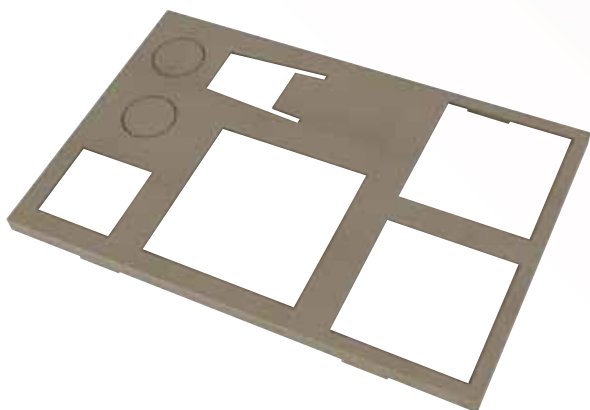
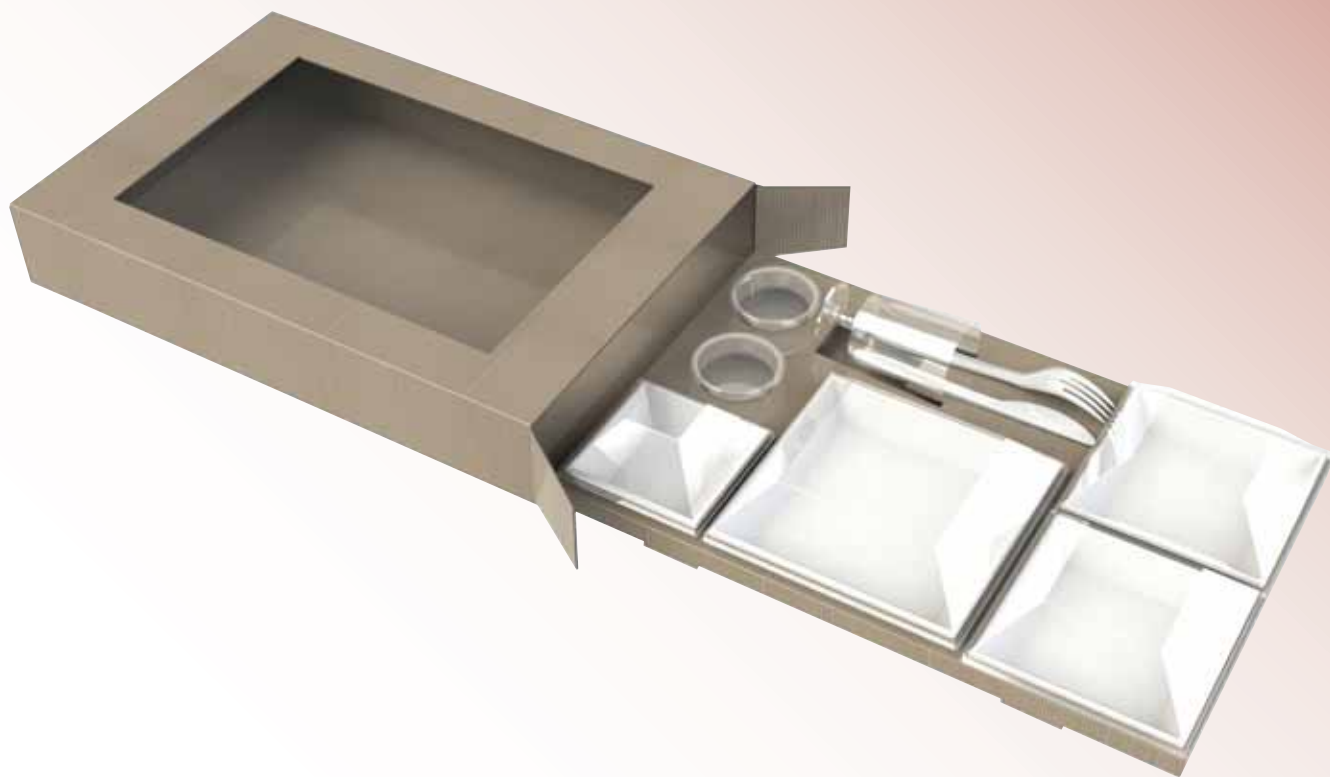

PLATEAU ÉTUI KRAFT EN CARTON

Kraft cardboard tray case

Caso bandeja de cartón kraft



450X290X70



1201450



50



CALAGE PLATEAU REPAS POUR ÉTUI KRAFT

Rigging tray meals

Aparejo bandejas de comida



280 x 435 x 21 mm



1201450CAL



50

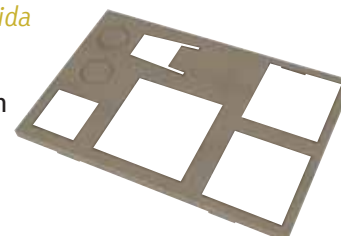

Dimensions
Dimensions



Capacité
Capacity



Référence
Reference



Conditionnement
Packaging

Plateaux repas - Combo

le «Kraft'n go»

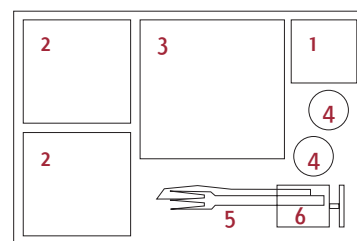

COMPOSITION : ESMERALDA

1 personne

1 - ASSIETTE «JADE» PS TRANSPARENT VERT
«JADE» PS transparent green plate
Plato PS verde transparente

90 x 90 x 15 mm
 11315009
 200



1 - COUVERCLE «JADE» PS TRANSPARENT VERT
«JADE» PS transparent green lid
Tapa «JADE» PS verde transparente

95 x 95 x 35 mm
 11315009COV
 200

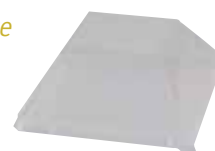

2 - ASSIETTE «JADE» PS TRANSPARENT VERT
'JADE' Transparent Green Plate
Plato PS verde transparente

X2

130 x 130 x 15 mm
 11315013
 200



2 - COUVERCLE ASSIETTE «JADE» PS TRANSPARENT VERT
'JADE' Transparent Green Lid
Tapa PS verde transparente

X2

135 x 135 x 35 mm
 11315013COV
 200

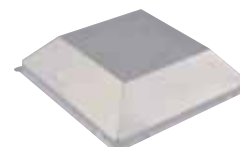

3 - ASSIETTE «JADE» PS TRANSPARENT VERT
'JADE' Transparent Green Plate
Plato PS verde transparente

160 x 160 x 15 mm
 11315016
 200



3 - COUVERCLE ASSIETTE «JADE» PS TRANSPARENT VERT
'JADE' Transparent Green Lid
Tapa PS verde transparente

165 x 165 x 35 mm
 11315016COV
 200



4 - POT À SAUCE PS 6 cl
PS condiment container - Bote PS para salsa

6 cl
 09POT200
 2500 (25X100)



4 - COUVERCLE PS TRANSPARENT
Transparent lid for condiment container
Tapa transparente para bote de salsa

6 cl
 09POTL2
 2500 (25X100)



5 - SACHET COUVERTS PS TRANSPARENT 6 EN 1
(Couteau, Fourchette, Cuillère, Serviette, sel et poivre)

180 mm
 1500661
 250



6 - VERRE À PIED PS TRANSPARENT
PS transparent stemmed glass
Copa PS transparente

17 cl
 GK20
 250



Plateaux repas - Combo

le «Kraft'n go»

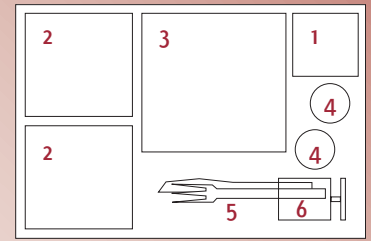

COMPOSITION : LE SOLO WHITE

1 personne

1 - RAVIER BLANC EN PS + COUVERCLE TRANSPARENT APET
WHITE RIBBON IN PS + COVER TRANSPARENT APET
BLANCO BOWL + TAPA TRANSPARENTE PS APET

135 x 135 x 20 mm
 1131014B
 200



3 - RAVIER BLANC EN PS + COUVERCLE TRANSPARENT APET
WHITE RIBBON IN PS + COVER TRANSPARENT APET
BLANCO BOWL + TAPA TRANSPARENTE PS APET

100 x 100 x 20 mm
 1131013B
 200



2 - RAVIER BLANC EN PS + COUVERCLE TRANSPARENT APET
WHITE RIBBON IN PS + COVER TRANSPARENT APET
BLANCO BOWL + TAPA TRANSPARENTE PS APET **X2**

170 x 170 x 20 mm
 1131012B
 200



4 - POT À SAUCE PS 6 CL
PS condiment container - Bote PS para salsa

6 cl
 09POT200
 2500 [25X100]



5 - SACHET COUVERTS PS TRANSPARENT 6/1
(COUTEAU, FOURCHETTE, CUILLÈRE, SERVIETTE, SEL ET
POIVRE

6-in-1 PS pack of transparent cutlery

180 mm
 1500661
 250



4 - COUVERCLE PS TRANSPARENT
Transparent lid for condiment container
Tapa transparente para bote de salsa

6 cl
 09POTL2
 2500 [25X100]



6 - VERRE À PIED PS TRANSPARENT
PS transparent stemmed wine glass
Copa PS transparente

17 cl
 GK20
 250 [25X10]



Dimensions
Dimensions



Capacité
Capacity



Référence
Reference



Conditionnement
Packaging

Plateaux repas - Combo

le «Kraft'n go»

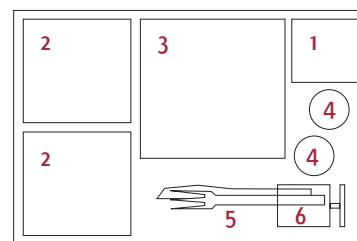

COMPOSITION : PULP'N KRAFT



1 personne

1 - RAVIER PULPE BLANC

Ravier white pulp
Ravier pulpa blanca

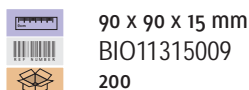

1 - COUVERCLE POUR RAVIER PULPE BLANC EN APET

Cover for ravier white pulp
cobertura de la pulpa blanca ravier

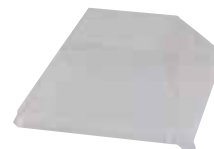
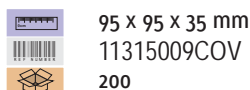

2 - RAVIER PULPE BLANC

Ravier white pulp
Ravier pulpa blanca

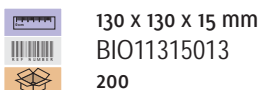

X2

2 - COUVERCLE POUR RAVIER PULPE BLANC EN APET

Cover for ravier white pulp
cobertura de la pulpa blanca ravier

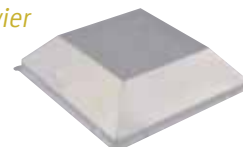
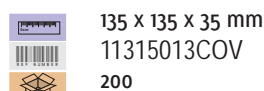

X2

3 - RAVIER PULPE BLANC

Ravier white pulp
Ravier pulpa blanca

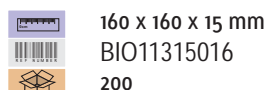

3 - COUVERCLE POUR RAVIER PULPE BLANC EN APET

Cover for ravier white pulp
cobertura de la pulpa blanca ravier

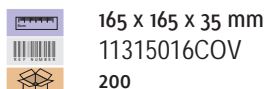

4 - MINI POT CRISTAL EN PLA 60 ML

Mini crystal pot 60 ml PLA
Pote de cristal de 60 ml Mini PLA

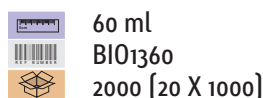

4 - COUVERCLE EN PLA POUR MINI POT 60 ET 80 ML EN PLA

Cover pla mini pot for 60 and 80 ml
Cubrir el mini pote pla de 60 y 80 ml

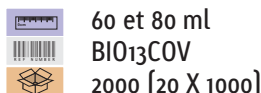

5 - SACHET SOUVERTS LUXE 4 EN 1 BIODÉGRADABLE

Luxury bag covered 4 in 1 biodegradable
Bolsa de lujo cubierto 4 en 1 biodegradables

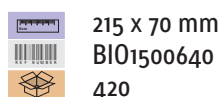

6 - GOBELET PLA TRANSPARENT 20/23CL

PLA transparent cup 20/23cl
PLA taza transparente 20/23cl

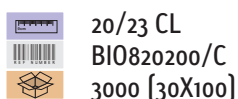

Plateaux repas - Combo

le «Kraft'n go»

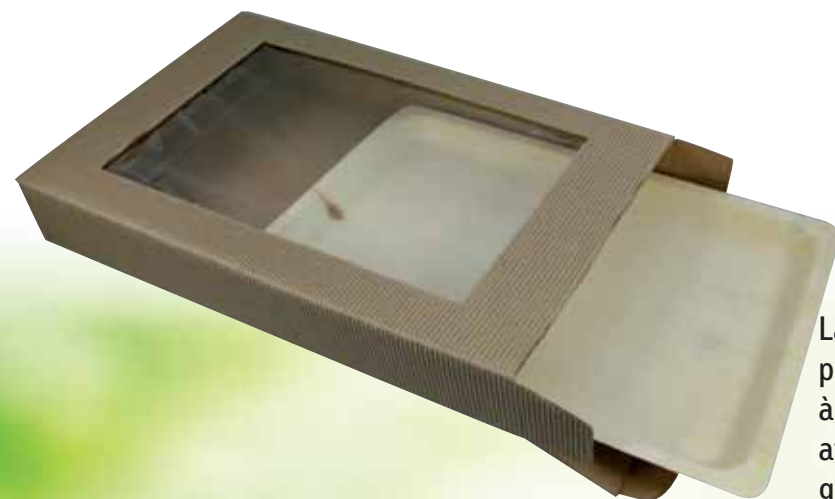
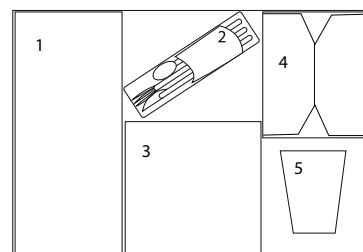

La Gamme «VISION VERTE» fabriquée à partir de pulpe de canne à sucre est idéale pour la vente à emporter. Ces contenants offrent de nombreux atouts : résistance et étanchéité aux sauces et aux graisses, micro-ondables jusqu'à 220 °C.

COMPOSITION : PULP INSTINCT



1 personne

1 - ASSIETTE PULPE BLANCHE

White cellulose plate - Plato pulpa blanco

130 x 260 x 20 mm
115211326
300 (12x25)



3 - ASSIETTE PULPE BLANCHE

Square cellulose plate - Plato pulpa cuadrado

170 x 170 x 15 mm
1152117
300 (12x25)



1 bis - COUVERCLE TRANSPARENT PET POUR ASSIETTE PULPE BLANCHE 130 x 260 mm

PET transparent lid for cellulose plate
Tapa PET transparente para plato pulpa blanco

145 x 275 mm
115211326COV
300 (6x50)



3 bis - COUVERCLE TRANS. ASSIETTE PULPE 170 x 170

RPET Lid for cellulose plate - Tapa PET-R plato pulpa cuadrada

180 x 180 x 40 mm
1152117COV
300 (6x50)



2 - SACHET COUVERTS 3 EN 1 LUXE BIODÉGRADABLE (Couteau+Fourchette+Serviette)

3-in-1 pack of Biodegradable Cutlery
(Knife + Fork + Serviette)

270 x 75 x 15 mm
BIO1500630
500



4 - BOITE FIRPACK CARTON RECYCLÉ KRAFT BRUN

«FIRPACK» brown recycled cardboard box
Caja de cartón kraft reciclado «FIRPACK» marrón

755 ml
BIO1330130
450



PLATEAU BOIS 280 x 420

Wooden plate - Madera placa

280 x 420 mm
BIO280420
100



5 - GOBELET PULPE BLANC 20/26 cl

Cellulose Tumbler - Vaso de pulpa

20-26 cl
BIO826200
750 (30x25)



Dimensions
Dimensions



Capacité
Capacity



Référence
Reference



Conditionnement
Packaging

Plateaux repas - Combo

l'ETUI «KRAFT BRUN»



ETUI KRAFT BRUN + CALAGE

*Brown cardboard case
Estuche kraft marrón*

	340 x 180 x 90 mm
	1200340
	50



COLLECTION «ESMERALDA»

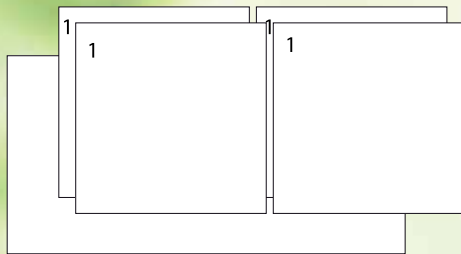

ÉTUI «KRAFT BRUN»
Empilez quatre assiettes !

1 - ASSIETTE PS INJECTÉ VERT TRANSPARENT

TPS transparent green plate - Plato PS verde transparente

	160 x 160 x 20 mm
	11315016
	200



1 bis - COUVERCLE PET TRANSPARENT

POUR ASSIETTE PS INJECTÉ 160 x 160

Transparent PET lid - Tapa PET verde transparente

	165 x 165 x 40 mm
	11315016COV
	200

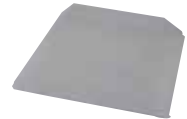

COLLECTION «PULP INSTINCT»

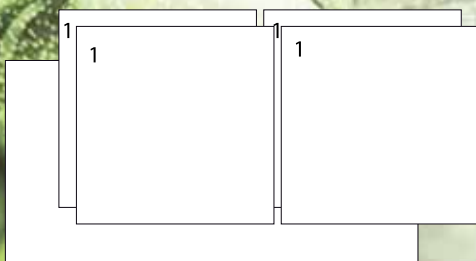

1 - ASSIETTE PULPE BLANCHE

Square cellulose plate - Plato pulpa cuadrado

	170 x 170 x 15 mm
	1152117
	300 (12x25)



1 bis - COUVERCLE RPET TRANSPARENT

POUR ASSIETTE PULPE 170 x 170

RPET lid for cellulose plate - Tapa PET-R para plato pulpa

	180 x 180 x 40 mm
	1152117COV
	300 (6x50)



Dimensions
Dimensions

Capacité
Capacity

Référence
Reference

Conditionnement
Packaging

Plateaux repas - Combo

LE « MUST »



Ce plateau ne contient pas de couverts



Ce plateau ne contient pas de verre

Le plateau «MUST» version «Light» dispose d'une ergonomie et d'une résistance permettant un transport en toute sécurité des repas.



PLATEAU COFFRET «PRESTIGE» CARTON IVOIRE

«PRESTIGE» transport box - caja «PRESTIGE» cartón marfil



400 x 300 x 70 mm
20BT395PPT
50

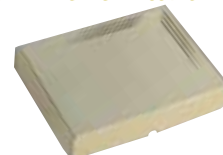

AVEC TIROIR

TIROIR CARTON BLANC POUR COFFRET «MUST»

White cardboard drawer for «MUST» tray
Bandeja blanca para caja «MUST»



380 x 290 x 30 mm
20PL395TIROIR
100



VERRE À PIED PS TRANSPARENT

Transparent PS stemmed glass
Copa PS transparente



17 cl
GK20
250 (25x10)



ASSIETTE PET BLANCHE 135 x 135 x 20 AVEC COUVERCLE PET TRANSPARENT

PET medium white plate + lid
Plato mediano PET blanca + tapa



135 x 135 x 20 mm
1131014B
200 + 200



ASSIETTE PET BLANCHE 170 x 170 x 20 AVEC COUVERCLE PET TRANSPARENT

PET large white plate + lid
Plato grande PET blanca + tapa



170 x 170 x 20 mm
1131012B
200 + 200



RAVIER PET 100 x 100 AVEC COUVERCLE PET BLANC TRANSPARENT

PET small transparent green plate + lid
Fuente pequeña PET verde transparente + tapa



100 x 100 mm
1131013B
200 + 200



ASSIETTE PET BLANCHE 170 x 100 AVEC COUVERCLE PET VERT TRANSPARENT

PET white plate + lid
Plato blanco PET + tapa



170 x 100 x 20 mm
1131018B
200 + 200



Dimensions
Dimensions



Capacité
Capacity



Référence
Reference



Conditionnement
Packaging

Plateaux repas - Combo

LE « MUST »





Ce plateau ne contient pas de couverts



AVEC INSERT

PLAQUE DÉCOUPÉE BLANCHE



White segmented plate - Plancha troquelada blanca

 480 x 380 x 70 mm
 20PL395PPT/C
 100



POT À SAUCE PS 3 cl



PS condiment container - Bote PS para salsa

 3 cl - 1 oz
 09POT100
 5000 (20x250)



COUVERCLE PS TRANSPARENT



Transparent lid for condiment container
 Tapa transparente para bote de salsa

 3 cl
 09POTL1
 2500 (25x100)



VERRE À PIED PS TRANSPARENT



Transparent PS stemmed glass
 Copa PS transparente

 17 cl
 GK20
 250 (25x10)



BOL OREILLES PP BLANC



White PP bowl with handles - Bol con asas PP blancoblanco

 350 CC
 1430350N2
 720 (12x60)



COUVERCLE PP TRANSPARENT POUR BOL OREILLES



PP transparent lid for white bowl with handles
 Tapa PP transparente para bol con asas

 1430350COUV
 648



BARQUETTE PP BLANC 250 gr



White PP container - Cesta PP blanca

 137 x 95 x 30 mm
 3140250
 1800 (12x150)



BARQUETTE «SURF» PP BLANCHE



White «SURF» container - Recipiente blanco «SURF»

 160 H 45
 1210450
 592



BARQUETTE PP 750 gr BLANCHE

White PP container - Cesta PP blanca

 190 x 137 x 42 mm
 3140750
 800 (16x50)





Plateaux repas - Combo

LA « LUNCH BOX »

PLATEAU SNACKING CARTON BLANC

White «SNACKING» cardboard take-away box
Caja blanca «SNACKING» cartón blanca

 255 x 190 x 160 mm
 0085559/C
 140



COMPOSITION : FRENCHY FOLIES

 2 personnes

1 - COCOTTE RONDE NOIRE PP 300 ML + COUVERCLE

Round black casserole + lid
Cazuelita redonda negra + tapa

 300 ml
 4020300N
 100



5 - KIT 4/1 INOX RÉUTILISABLE (FOURCHETTE + COUTEAU + CUILLÈRE + SERVIETTE)



4-in-1 pack of reusable stainless cutlery (fork + knife + spoon + serviette)
Kit reutilizable cubiertos de acero inoxidable 4 en 1
(cuchillo + cuchara + servilleta tenedor + cuchillo + cuchara + servilleta)

 -
 0093119
 100



2 - MINI BOCAL «TERROIR» PLASTIQUE 300 ML joint orange



«TERROIR» mini-jar in plastic
Minitarro «TERROIR» plástico

 300 ml
 8470300
 60 (10x6)



6 - GOBELET CARTON ÉPAIS SAVANE 10 CL

Cyp carton thick savannah 10cl
Vaso de carton double capa 10 cl

 10 cl - 4 oz
 8000661/C
 3000 (25x120)



3 - SALADIER ROND PET 34 CL - 12 OZ



Round PET salad bowl
Ensaladera redonda PET

 34 cl - 12 oz
 146012
 500 (20x25)



COUVERCLE BLANC DÔME



White dome lid
Tapa blanca

 4 OZ
 10LGC4
 3000 (30x100)



4 - MINI BOCAL «TERROIR» PLASTIQUE 300 ML joint orange

«TERROIR» mini-jar in plastic
Minitarro «TERROIR» plástico

 300 ml
 8470300
 60 (10x6)



COUVERCLE TRANSPARENT PLAT

Transparent COVER PLATE
Tapa cupula transparente

 4 OZ
 10LGC4S/C
 1000



Dimensions
Dimensions



Capacité
Capacity



Référence
Reference



Conditionnement
Packaging

Plateaux repas - Combo

LA « LUNCH BOX »

La boîte de transport «Snacking» en carton comprend des poignées adaptées pour le portage de repas. Pratique, l'emplacement spécial boisson ou dessert permet de transporter votre repas en toute tranquillité (boîte livrée à plat pour gagner de la place).



COMPOSITION : EMERALDA

2 personnes

1 - ASSIETTE «JADE» PS TRANSPARENT VERT

«JADE» PS transparent green plate
Plato PS verde transparente

90x90 mm
 11315009
 200



COUVERCLE «JADE» PS TRANSPARENT VERT

«JADE» PS transparent green lid
Tapa «JADE» PS verde transparente

-
 11315009COV
 200

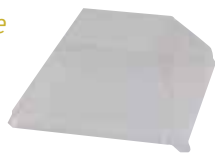

2 - ASSIETTE PS «JADE» TRANSPARENT VERT ET COUVERCLE

«JADE» PS transparent Green Plate and Lid
Plato PS «JADE» verde transparente y tapa

160x160 mm
 11315016
 200

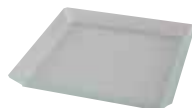

COUVERCLE «JADE» PS TRANSPARENT VERT

«JADE» PS transparent green lid
Tapa «JADE» PS verde transparente

-
 11315016COV
 200

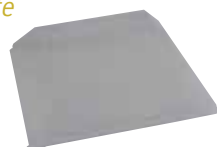

3 - KIT 4/1 INOX RÉUTILISABLE (FOURCHETTE + COUTEAU + CUILLÈRE + SERVIETTE)

4-in-1 pack of reusable stainless cutlery (fork + knife + spoon + serviette)
Kit reutilizable cubiertos de acero inoxidable 4 en 1
[cuchillo + cuchara + servilleta tenedor + cuchillo + cuchara + servilleta]

-
 0093119
 100



4 - GOBELET CARTON ÉPAIS SAVANE 10 CL

Cup carton thick savannah 10cl
Vaso de carton doble capa 10 cl

10 cl - 4 oz
 8000661/C
 3000 (25x120)



COUVERCLE BLANC DÔME

White dome lid
Tapa blanca

4 OZ
 10LGC4
 30 X 100



COUVERCLE TRANSPARENT PLAT

Transparent COVER PLATE
Tapa cupula transparente

4 OZ
 10LGC4S/C
 1000



Plateaux repas - Combo

LE « LUXE SOFT »



Ce plateau ne contient pas de couverts



Ce plateau ne contient pas de verre

Seul ou garnis, ce plateau sera ravir par ses lignes épurées !



Le Plateau «LUXE Soft» est idéal pour les traiteurs ou restaurateurs qui veulent présenter leurs préparations sur un plateau élégant, moderne et solide. Le coloris vert transparent du plateau repas permet d'ajouter une touche brillante et raffinée.

PLATEAU LUXE PS VERT TRANSPARENT

«LUXE PS transparent green plate
Bandeja PS verde



290 x 220 x 20 mm
0915029
50

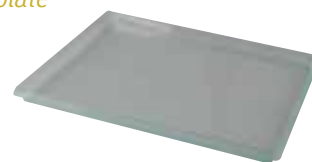

COUVERCLE PET VERT TRANSPARENT

Transparent PET lid
Tapa PET verde



330 x 255 x 50 mm
0915029COV
100

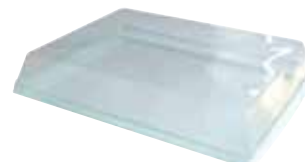

Dimensions
Dimensions



Capacité
Capacity



Référence
Reference



Conditionnement
Packaging

Plateaux repas - Combo

LE « LUXE SOFT »

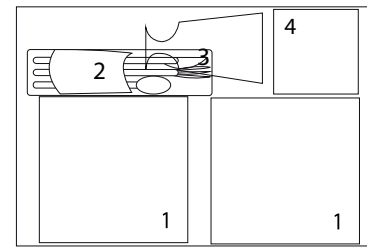

COMPOSITION : ESMERALDA

1 personne

1 - ASSIETTE PS INJECTÉ VERT TRANSPARENT 130 x 130

Transparent green PS plate
Plato PS transparente verde

X2

130 x 130 x 20 mm
11315013
200



2. 3 - ÉTUI COUVERT KRAFT «BON APPÉTIT» + SERVIETTE

«BON APPÉTIT» cutlery case + serviette

Estuche para cubiertos «BON APPÉTIT» + servilleta

200x85 mm
0900302
600



1 bis - COUVERCLE PET TRANSPARENT

Transparent PET lid
Tapa PET transparente

140 x 140 x 40 mm
11315013COV
200

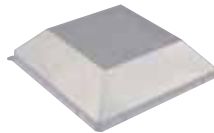

3 - VERRE À PIED PS TRANSPARENT

PS transparent stemmed glass
Copa PS transparente

17 cl
GK20
250 (25x10)



2 - FOURCHETTE TRANSPARENTE «GIVRÉE» PS

Frosted PS transparent fork
Tenedor PS transparente

180 mm
1513318
250 (10x25)



4 - ASSIETTE PS INJECTÉ VERT TRANSPARENT 90 x 90

Transparent green plate in PS
Plato PS verde transparente

90 x 90 x 20 mm
11315009
200



2.1 - COUTEAU TRANSPARENT «GIVRÉ» PS

Frosted PS transparent knife
Cuchillo PS transparente

190 mm
1523319
250 (10x25)



4 bis - COUVERCLE PET TRANSPARENT

Transparent PET lid
Tapa PET transparente

95 x 95 x 40 mm
11315009COV
200

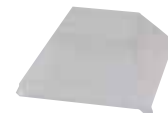

2.2 - CUILLERE TRANSPARENTE «GIVRÉE» PS

Frosted PS transparent knife
Cuchara PS transparente

170 mm
1533318
250 (10x25)



Plateaux repas - Combo

Collection « JADE »

Une gamme élaborée et structurée pour vos plats fins et gourmets. Cette proposition vous offre la possibilité de mêler deux grands ravier pour vos compositions. Un verre et un set couverts pour un plateau complet.

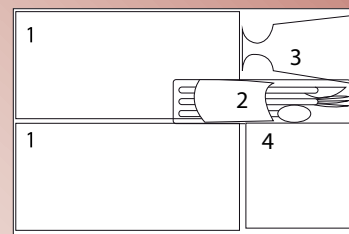

COMPOSITION : ESMERALDA

1 personne

1 - ASSIETTE PET BLANCHE RECTANGLE 170 x 100 + COUVERCLE PET TRANSPARENT **X2**
White plate + Lid in PET
Plato PET rectangular blanco + tapa

170 x 100 x 20 mm
 1131018B
 200 + 200

3 - VERRE À PIED PS TRANSPARENT
PS transparent stemmed glass
Copa PS transparente

17 cl
 GK20
 250 (25x10)

2 - KIT COUVERTS INOX RÉUTILISABLE (FOURCHETTE, COUTEAU, PETITE CUILLÈRE, SERVIETTE)
Pack of reusable stainless cutlery
[fork, knife, spoon, serviette]
Kit cubiertos de acero inoxidable
[tenedor, cuchillo, cuchara, servilleta] reutilizable

-
 0093119
 100

4 - RAVIER PET BLANCHE 100 x 100 + COUVERCLE PET TRANSPARENT
Small transparent + lid in PET
Fuente PET + tapa PET

100 x 100 mm
 1131013B
 200 + 200



Dimensions
Dimensions



Capacité
Capacity



Référence
Reference



Conditionnement
Packaging

Plateaux repas - Combo

LE «TOKUDAÏ»



Ce plateau ne contient pas de verre



Ce plateau ne contient pas de couverts

PLATEAU «TOKUDAÏ» 305x240 mm

«TOKUDAÏ» tray
Bandeja «TOKUDAÏ»

305x240 mm
 09153044
 100



COMPOSITION : ESMERALDA

1 personne

GRANDE ASSIETTE «TOKUDAÏ» PS 145x275 mm +COUVERCLE

PS large «TOKUDAÏ» plate
Plato PS grande «TOKUDAÏ»

145x275 mm
 113201427
 100



145x275 mm
 113201427COV
 100



PETITE ASSIETTE «TOKUDAÏ» APET 135x145mm +COUVERCLE

APET small «TOKUDAÏ» plate
Plato pequeño «TOKUDAÏ» APET

135x145 mm
 113201314/C
 100



135x145 mm
 113201314COV/C
 100



Pour compléter ce plateau, nous vous proposons :

FOURCHETTE TRANSPARENTE «GIVRÉE» PS

PS frosted transparent fork
Tenedor PS transparente

180 mm
 1513318
 250 (10x25)



VERRE À PIED PS TRANSPARENT

PS transparent stemmed glass
Copa PS transparente

17 cl
 GK20
 250 (25x10)



COUTEAU TRANSPARENT «GIVRÉ» PS

PS frosted transparent knife
Cuchillo PS transparente

190 mm
 1523319
 250 (10x25)



CUILLÈRE TRANSPARENTE «GIVRÉE» PS

PS frosted transparent spoon
Cuchara PS transparente

170 mm
 1533318
 250 (10x25)



ÉTUI COUVERT «BON APPÉTIT» + SERVIETTE

«BON APPÉTIT» cutlery case + serviette
Estuche para cubiertos «BON APPÉTIT» + servilleta

200x85 mm
 0900302
 600



sur commande
to order / de encargo



Dimensions
Dimensions



Capacité
Capacity



Référence
Reference



Conditionnement
Packaging

Plateaux repas - Solo

LE « LUXE 6 COMPARTIMENTS »



Ce plateau ne contient pas de couverts



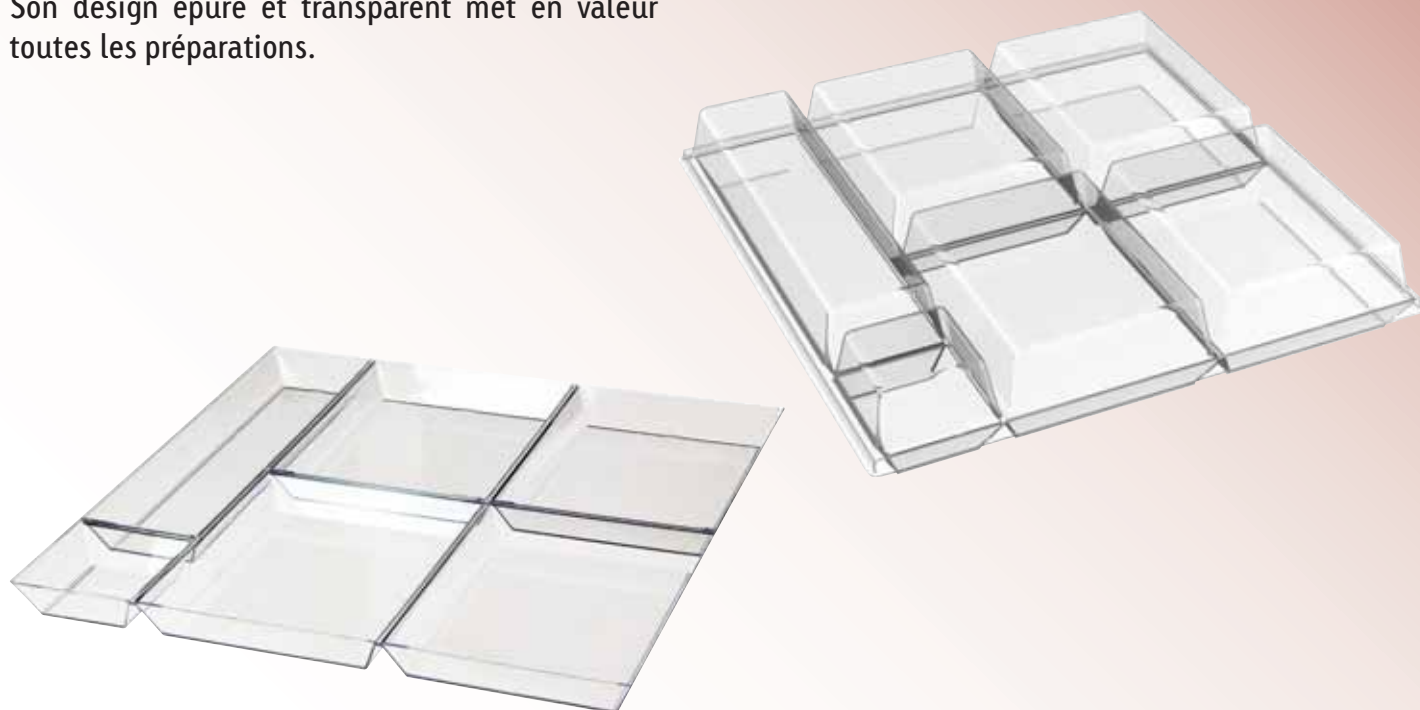

Ce plateau ne contient pas de verre

Le Plateau «LUXE» dispose de 6 compartiments adaptés aux couverts et divers contenants. Son design épuré et transparent met en valeur toutes les préparations.



PLATEAU «LUXE» 6 COMPARTIMENTS PS TRANSPARENT TRANSPARENT

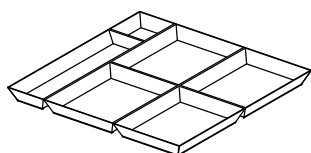

«LUXE» PS transparent green tray with 5 compartments
Bandeja PS verde transparente 5 compartimentos

 307 x 307 x 20 mm
 0915031/C
 25



COUVERCLE PET VERT TRANSPARENT

Transparent green PET lid
Tapa PET verde transparente

 323 x 323 x 40 mm
 0915031COV
 50

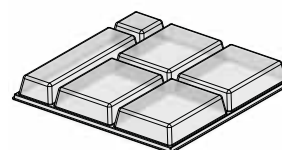

Pour compléter ce plateau, nous vous proposons :

KIT COUVERTS INOX RÉUTILISABLE (FOURCHETTE, COUTEAU, PETITE CUILLÈRE, SERVIETTE)

Pack of reusable stainless cutlery
{fork, knife, spoon, serviette}
Kit cubiertos de acero inoxidable
{tenedor, cuchillo, cuchara, servilleta} reutilizable

 -
 0093119
 100



VERRE À PIED PS TRANSPARENT

PS transparent stemmed glass
Copa PS transparente

 17 cl
 GK20
 250 [25x10]



Dimensions
Dimensions



Capacité
Capacity



Référence
Reference



Conditionnement
Packaging

Plateaux repas - Solo



LE «WOOD MOOD»



sur commande
to order / de encargo



PLATEAU «LUXE» BOIS

«LUXE» wooden tray - Bandeja «LUXE» madera

 274x380 h30 mm
 BIO274380
 100 [2x50]

COUVERCLE

lid - Tapa



 -
 BIO274380COV
 50





sur commande
to order / de encargo

RAVIER «LUXE» BOIS 215x85 MM

«LUXE» wooden dish - Pequeño plato «LUXE» madera

 215x85 h28 mm
 BIO215085
 100

COUVERCLE lid - Tapa



 -
 BIO215085COV
 100





sur commande
to order / de encargo

ASSIETTE «LUXE» BOIS 170x170 MM

«LUXE» wooden plate - Plato «LUXE» madera

 170x170 h20 mm
 BIO170170
 100

COUVERCLE / lid / Tapa



 -
 BIO170170COV
 100





sur commande
to order / de encargo

RAVIER «LUXE» BOIS 155x85 MM

«LUXE» wooden dish - Plato «LUXE» madera

 155x85 h28 mm
 BIO85155
 100



COUVERCLE / Lid / Tapa

 -
 BIO85155COV
 100





ASSIETTE «LUXE» BOIS 130x180 MM

«LUXE» wooden plate - Plato «LUXE» madera

 130x180 h28 mm
 BIO130180
 100

COUVERCLE lid - Tapa

 -
 BIO130180COV
 100



sur commande
to order / de encargo



Plateaux repas - Solo

LE « PULPY 3 »



Fabriqué à partir de pulpe de canne à sucre, ce plateau offre de nombreux atouts : résistant et étanche aux sauces et aux graisses, il dispose de 3 compartiments permettant de présenter un repas complet accompagné de couverts.

Demandez
notre nouveau
catalogue
Vision verte



PLATEAU PULPE 5 COMPARTIMENTS

Cellulose tray
Bandeja pulpa



320 x 215 mm
13533020
200 (4x50)



Dimensions
Dimensions



Capacité
Capacity



Référence
Reference



Conditionnement
Packaging

Plateaux repas - Solo

LE « PULPY 5 »



1352822



1353827

Petit format

PLATEAU PULPE 5 COMPARTIMENTS

Cellulose tray
Bandeja de pulpa



280 x 220 x 35 mm
1352822
200 (4x50)



COUVERCLE PULPE POUR PLATEAU PULPE

Cellulose lid for cellulose tray
Tapa pulpa para bandeja pulpa



295 x 240 mm
1352822COV
200 (4x50)



Grand format

PLATEAU PULPE 5 COMPARTIMENTS

Cellulose tray
Bandeja pulpa



375 x 270 x 30 mm
1353827
200 (4x50)



COUVERCLE TRANSPARENT RPET

Transparent RPET lid for cellulose tray
Tapa transparente PET-R para bandeja pulpa



385 x 275 x 45 mm
1353827COV
100



Matériau recyclé = RPET

Avec ces plateaux, nous vous proposons :

SACHET COUVERTS 3 EN 1 LUXE BIODÉGRADABLE

(Couteau+Fourchette+Serviette)
3-In-1 pack of biodegradable cutlery

[Knife + fork + serviette]
Bolsita de cubiertos 3 en 1 [cuchillo + tenedor + servilleta]



270 x 75 x 15 mm
BIO1500630
500



SACHET 3/1 BOIS (Couteau+Fourchette+Cuillère)

3-In-1 pack of wooden cutlery [knife + fork + spoon]
Bolsita cubiertos 3 en 1 madera

[Cuchillo + tenedor + cuchara]



165 mm
1590630/C
300



GOBELET PULPE 26 CL

Cellulose tumbler - Vaso de pulpa



20-26 cl / 9 oz
BIO826200
750 (30x25)



SERVIETTE Papier recyclé marron 1 pli

1-Ply brown recycled paper serviette
Servilleta de papel reciclado marrón 1 capa



30x30 mm
611113/C
3200 (16x200)



Plateaux repas - Solo

le « VAGUE »



Ce plateau ne contient pas de couverts



Ce plateau ne contient pas de verre

Le Plateau «VAGUE» est idéal pour les traiteurs à la recherche de vaisselle aux lignes fines et épurées...

Choisissez vos couleurs,
Idéal quand on propose 2 menus !



Il est composé d' 1 assiette noire,
1 couvercle transparent,
2 ravier 1/4 bordeaux ou beige
et 1 ravier 1/2 bordeaux ou beige.

PLATEAU «VAGUE» PS BORDEAUX

Red «VAGUE» Tray in PS
Bandeja «VAGUE» PS rojo



245 x 245 mm



1131001



100



PLATEAU «VAGUE» PS BEIGE

Beige «VAGUE» Tray in PS
Bandeja «VAGUE» PS blanco



245 x 245 mm



1131011



100



Dimensions
Dimensions



Capacité
Capacity



Référence
Reference



Conditionnement
Packaging

Plateaux repas - Solo



Ce plateau ne contient pas de verre



Ce plateau ne contient pas de couverts

le « SALADIER WAN »

le « PLAT OSARA »

GAMME UENO

GAMME UENO -



SOUS-ASSIETTE «WAN» PS 215x215 MM

«WAN» service plate
Bajoplato «WAN»



215x215 mm
11354215
100

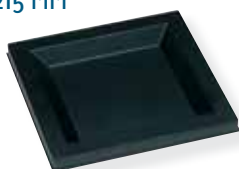

SOUS-ASSIETTE «OSARA» PS

«OSARA» Service Plate
Bajoplato Plat «OSARA»

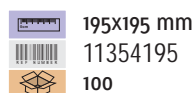

195x195 mm
11354195
100



COUVERCLE «WAN» APET 215x215 MM

Lid for «WAN» Service Plate
Tapa para bajoplato «WAN»

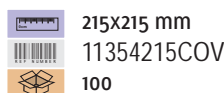

215x215 mm
11354215COV
100



COUVERCLE «OSARA» APET

Cover for ueno «OSARA» service platetapa para bajo plato tapa para bajoplato ueno plat osara

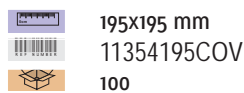

195x195 mm
11354195COV
100



SALADIER «WAN» PS 200x200 MM

«WAN» Salad Bowl
Ensaladera «WAN»

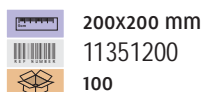

200x200 mm
11351200
100



ASSIETTE PLAT «OSARA» PS

«OSARA» Plate
Plato Plat Osara

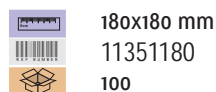

180x180 mm
11351180
100



Pour compléter ce plateau, nous vous proposons :

KIT COUVERTS INOX RÉUTILISABLES

(fourchette, couteau, cuillère, serviette)

Pack of reusable stainless cutlery

(fork, knife, spoon, serviette)

Kit cubiertos de acero inoxidable (tenedor, cuchillo, cuchara, servilleta)



-
0093119
100



VERRE À PIED PS TRANSPARENT

PS transparent stemmed glass

Copa PS transparente

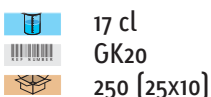

17 cl
GK20
250 (25x10)



Plateaux repas - Solo



Ce plateau ne contient pas de verre



Ce plateau ne contient pas de couverts

le « PLATEAU OOKI »

le « PLATEAU CHISAÏ »



GAMME UENO

GAMME UENO -



PLATEAU «OOKI» PS

«OOKI» Tray
Bandeja «OOKI»

 380x275 mm
 09123827
 50



SOUS-ASSIETTE «CHISAI» PS 245x245 MM



«CHISAI» service plate
Bajoplato «CHISAI»

 245x245 mm
 09122424
 100



COUVERCLE «OOKI» APET



«OOKI» lid
Tapa «OOKI»

 380x275 mm
 09123827COV
 50



COUVERCLE «CHISAI» APET 245x245 MM



Lid for «CHISAI» service plate
Tapa para bajo plato «CHISAI»

 245x245 mm
 09122424COV
 100



RAVIER «OOKI» 1/2 PS 130x260 mm



«OOKI» 1/2 dish
Fuente «OOKI» 1/2

 130x260 mm
 113211326
 50



RAVIER «CHISAI» 1/2 PS 115x225 MM



«CHISAI» 1/2 Dish
Fuente «CHISAI» 1/2

 115x225 mm
 113211122
 100



RAVIER «OOKI» 1/4 PS 130x130 mm



«OOKI» 1/4 Dish
Fuente «OOKI» 1/4

 130x130 mm
 113211313
 100



RAVIER «CHISAI» PS 1/4 115x115 MM

«CHISAI» 1/4 Dish
Fuente «CHISAI» 1/4

 115x115 mm
 113211111
 200



Dimensions
Dimensions



Capacité
Capacity



Référence
Reference



Conditionnement
Packaging

Plateaux repas - Solo

« LE CUBE »



Ce plateau ne contient pas de couverts





Ce plateau ne contient pas de verre

Empilez vos idées



PLATEAU «CUBE» APET NOIR + 2/1 RAVIER PS + 2/4 RAVIER PS + COUVERCLE APET
Black «CUBE» tray in APET + 1 1/2 Dish + 2 1/4 dishes in PS and Lid in APET
Bandeja «CUBE» PET negro + 2/1 fuente PS + 2/4 fuente PS + tapa PET

 305x320 mm
 09113032
 50



Le plateau par excellence qui révolutionne la vente à emporter.

Pour compléter ce plateau, nous vous proposons :

KIT COUVERTS INOX RÉUTILISABLE (FOURCHETTE, COUTEAU, CUIILLÈRE, SERVIETTE)



Pack of reusable stainless cutlery (fork, knife, spoon, serviette)
Kit cubiertos de acero inoxidable (tenedor, cuchillo, cuchara, servilleta) reutilizable

 -
 0093119
 100



VERRE À PIED PS TRANSPARENT

PS transparent stemmed wine glass
Copa PS transparente

 17 cl
 GK20
 250 (25x10)



Plateaux repas - Solo

LE « PAUSE DÉJEUNER »



Destiné notamment aux collectivités, la gamme «PAUSE DEJEUNER» allie qualité et modularité. Pratique, ce plateau dispose de 5 compartiments et d'un couvercle (vendu séparément).

PLATEAU «PAUSE DEJEUNER» PS BEIGE

Ivory «PAUSE DEJEUNER» (lunch break) tray
Bandeja PS «PAUSE DEJEUNER»



342 X 242 X 30 mm
0915019
200



COUVERCLE PS TRANSPARENT

Transparent lid
Tapa PS transparente



345 X 245 X 30 mm
0915019COV
200



Pour compléter ce plateau, nous vous proposons :

GOBELET PS «CRISTAL» TRANSPARENT 20/23 CL

«CRISTAL» tumbler - Vaso «CRISTAL»



20-23 cl
82212500
1000 (20x50)



SACHET 6/1 BLANC : FOURCHETTE + COUTEAU + PETITE CUILLERE + SERVIETTE + POIVRE & SEL

6-In-1 pack of transparent cutlery
(fork + knife + spoon + serviette + salt & pepper)
Bolsita cubiertos blancos 6 en 1 : tenedor + cuchillo + cuchara de postre + servilleta + sal y pimienta



-
1500660
250



Dimensions
Dimensions



Capacité
Capacity



Référence
Reference



Conditionnement
Packaging

Plateaux repas - Solo

LE «PRESTIGE»

Le Plateau «Prestige» est un kit complet esthétique grâce à sa forme originale.

Nous vous simplifions la vie, ce plateau est déjà complet !



Il est composé de 2 ravers ovoïdes blancs, 2 ravers quart de cercle blancs, 1 assiette blanche **micro-ondable**, 1 verre à pied cristal 20cl, 1 sachet couverts 6 en 1 standard (couteau, fourchette, petite cuillère, serviette, sel et poivre) et 1 couvercle transparent.

Ce plateau existe en 2 coloris : noir ou bordeaux.



PLATEAU «PRESTIGE» PS NOIR

Black «PRESTIGE» tray with 6 compartments + 4 white ramekins + 1 microwavable plate + 1 wine glass + 6-in-1 cutlery
Bandeja «PRESTIGE» 6 compartimentos: 4 fuentes blancas +plato para microondas+vaso +bolsita de cubiertos +tapa transparente



465 x 300 x 63 mm
4005610
50



PLATEAU «PRESTIGE» PS BORDEAUX

Burgundy «PRESTIGE» tray with 6 compartments + 4 white ramekins + 1 microwavable plate + 1 wine glass + 6-in-1 cutlery pack + transparent lid
Bandeja «PRESTIGE» 6 compartimentos : 4 fuentes blancas+plato para microondas+vaso+bolsita de cubiertos +tapa transparente



465 x 300 x 63 mm
4005620
50



Plateaux repas - Solo

LE « PLAT DU JOUR »



PLATEAU «PLAT DU JOUR» BORDEAUX

«PLAT DU JOUR» (daily special) tray with 5 compartments + 3 ivory ramekins + 1 burgundy tray + transparent lid
Bandeja burdeos «PLAT DU JOUR» 5 compartimentos : 3 fuentes + tapa transparente



265 x 370 x 60 mm
0915000
50



Le Plateau «PLAT DU JOUR» combine design et praticité avec ses 5 compartiments.

Il est composé d'une assiette et deux ravers ivoires ainsi que d'un couvercle transparent.

A savoir que seuls les ravers ivoires sont micro-ondables.

Pour compléter ce plateau, nous vous proposons :

SACHET COUVERTS PS TRANSPARENT 6 EN 1 (Couteau, Fourchette, Cuillère, Serviette, sel et poivre)

6-In-1 PS pack of transparent cutlery (fork + knife + spoon + serviette + salt & pepper)
Bolsita cubiertos PS transparente 6 en 1: tenedor + cuchillo + cuchara de postre + servilleta + sal y pimienta



180 mm
1500661
250



VERRE «CRISTAL» PS OCTOGONAL 25 cl

Octogonal «CRISTAL» tumbler
Vaso «CRISTAL» octogonal



25 cl
7023/C
600 [20x30]



Dimensions
Dimensions



Capacité
Capacity



Référence
Reference



Conditionnement
Packaging

Plateaux repas - Solo

« LE SCELLABLE »



Le plateau «THERMOSCELLABLE» est destiné aux collectivités. De part son ergonomie et ses 4 compartiments, il apporte une solution pratique de distribution des repas.

Notre Scelleuse La Scellinov



PLATEAU THERMOSCELLABLE GN₁/2 PP BLANC



White PP heat-Sealable tray GN₁/2
Bandeja termosellable GN₁/1 PP blanca

 322,5 x 262,5 x 36 mm
 EVM13458
 200



FILM SOUDABLE PET 12-PP30/PP

PET Tape for heat sealing 12-PP30/PP
Film para sellar PET 12-P30/PP

 Existe en différentes laizes et longueurs
 FRO30
 1



Plateaux repas - Solo

PLATEAU « LE STANDARD » EN PS

Destiné aux collectivités, le plateau «STANDARD» dispose de 6 compartiments pour une séparation de chaque élément du repas. Grâce à son couvercle adapté, il est totalement hermétique (couvercle vendu séparément).



COUVERCLE PS TRANSPARENT POUR PLATEAU STANDARD

*Transparent lid for standard white PS tray
Tapa PS transparente para bandeja estándar*



371 x 271 x 34 mm
PRC3727
150



PLATEAU STANDARD PS BLANC 6 COMPARTIMENTS

*Meal trays 5 compartments
Bandeja PS blanca estándar 6 compartimientos*



371 x 271 x 34 mm
PR3727
150 (6x25)



PLATEAU REPAS 5 COMPARTIMENTS

Qualité et modularité sont les principaux atouts de ce plateau repas.

Pratique, ce plateau dispose de 5 compartiments et d'un couvercle (vendu séparément).

Un plateau repas notamment destiné aux collectivités ...



PLATEAU REPAS 5 COMPARTIMENTS EN PS BEIGE

*Meal tray 5 compartments in beige ps
Bandeja de comida 5 compartimentos ps amarillento*



342x242 mm
0915019
200



COUVERCLE POUR PLATEAU 5 COMPARTIMENTS

*Lid for 5-compartment tray
Tapa de la bandeja 5 compartimientos*



345x245 mm
0915019COV
200



Dimensions
Dimensions



Capacité
Capacity



Référence
Reference



Conditionnement
Packaging

Assiettes

◆ *Esmeralda*

Assiette Goutte d'Eau
Assiette en thermoformé
Assiette en PS Jade
Assiette Vague

◆ *Frenchy folies*

Assiette Carré
Assiette Eightie
Saladier an
Plat Osara
Assiette Cocktail
Assiette Luxe Bois
Collection Bois « Peuplier »
Assiette Pulpe





Assiettes - Esmeralda

ASSIETTE EN PET « GOUTTE D'EAU EN THERMOFORMÉ »

Chez nous, la goutte d'eau ne fait jamais déborder le vase !





**GRANDE ASSIETTE «BLANCHE» PET
+ COUVERCLE TRANSPARENT PET**
PET large «white» plate + lid
Plato grande «blanca» PET con tapa

 170x170x20 mm
 1131012B
 200+200





**ASSIETTE «BLANCHE» PET RECTANGLE
+ COUVERCLE TRANSPARENT PET**
PET rectangular «WHITE» plate + lid
Plato rectangular «blanca» PET con tapa

 170x100x20 mm
 1131018B
 200+200





**MOYENNE ASSIETTE «BLANCHE» PET
+ COUVERCLE TRANSPARENT PET**
PET medium «white» plate + lid
Plato mediano «blanca» PET con tapa

 135x135x20 mm
 1131014B
 200+200



**RAVIER «BLANC» PET + COUVERCLE
+ COUVERCLE TRANSPARENT PET**
PET «white» dish + lid
Fuente «blanca» PET con tapa

 100x100x20 mm
 1131013B
 200+200



Pour présenter ces assiettes,
nous vous proposons :

PLATEAU «FAMOUS BREAK» (Réf. 1201367) Page 55



Dimensions
Dimensions



Capacité
Capacity



Référence
Reference



Conditionnement
Packaging

Assiettes - Esmeralda

ASSIETTE EN PS « JADE »

- › résistantes
- › effet verre

Touché d'Émeraude, le Luxe par excellence !!



11315009



11315013



11315016





1500661



GK20



ASSIETTE PS «JADE» TRANSPARENT VERT ET COUVERCLE
«JADE» PS transparent Green Plate and Lid
Plato PS «JADE» verde transparente y tapa

assiette

 160x160 mm
 11315016
 200



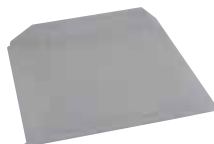

couvrele

 -
 11315016COV
 200





ASSIETTE PS «JADE» TRANSPARENT VERT ET COUVERCLE
PS «JADE» transparent green plate and lid
Plato «JADE» PS verde transparente y tapa

assiette

 130x130 mm
 11315013
 200



couvrele

 -
 11315013COV
 200

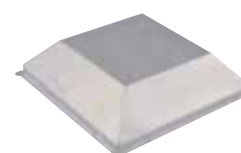



ASSIETTE PS «JADE» TRANSPARENT VERT ET COUVERCLE
PS «JADE» transparent green plate and lid
Plato «JADE» PS verde transparente y tapa

assiette

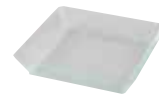
 90x90 mm
 11315009/C
 200



couvrele

 -
 11315009COV
 200

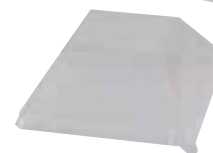

Pour présenter ces assiettes, nous vous proposons :

SACHET COUVERTS PS TRANSPARENT 6 EN 1
(Couteau, Fourchette, Cuillère, Serviette, sel et poivre)
6 -In-1 PS pack of transparent cutlery
(fork + knife + spoon + serviette + salt & pepper)
Bolsita PS cubiertos ps transparentes 6 en1: cuchillo +
tenedor + cuchara de postre + servilleta + sal y pimienta

 180 mm
 1500661
 250



VERRE À PIED PS TRANSPARENT
PS transparent stemmed glass
Copa PS transparente

 17 cl
 GK20
 250 (25x10)



Assiettes - Frenchy folies

ASSIETTE « VAGUE »

Soyez à la page !



1131002



1131006



1131009



1131003



1131003



1131008

ASSIETTE «VAGUE» NOIRE 21x21 CM

Black «VAGUE» plate
Plato «VAGUE» negro

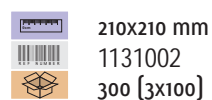

210x210 mm
1131002
300 {3x100}



ASSIETTE «VAGUE» NOIRE 24,5x24,5 CM

Black «VAGUE» plate
Plato «VAGUE» negro

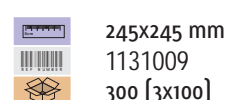

245x245 mm
1131009
300 {3x100}



ASSIETTE «VAGUE» BORDEAUX 21x21 CM

Burgundy «VAGUE» Plate
Plato «VAGUE» burdeos

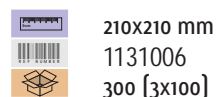

210x210 mm
1131006
300 {3x100}



COUVERCLE PET TRANSPARENT «VAGUE» 24,5x24,5 CM

Transparent PET lid for «VAGUE» plate
Tapa transparente para plato «VAGUE»



245x245 mm
1131008
300 {3x100}



COUVERCLE PET TRANSPARENT «VAGUE» 21x21 CM

Transparent PET Lid for «VAGUE» plate
Tapa PET transparente para plato «VAGUE»

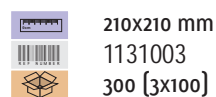

210x210 mm
1131003
300 {3x100}

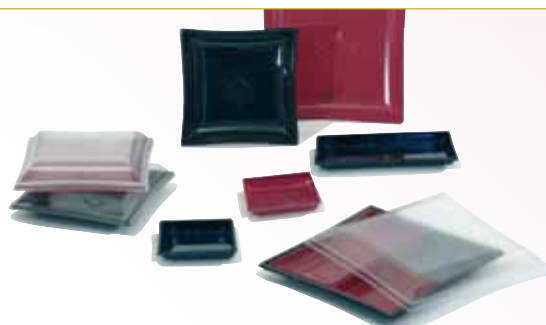

**SALADIER WAN
GAMME UENO**

GAMME UENO -

**DANS LA MÊME
LIGNE GRAPHIQUE
RETROUVEZ
NOTRE SALADIER WAN
ET PLAT OSARA
PAGES 97**



**PLAT OSARA
GAMME UENO**

GAMME UENO -



Dimensions
Dimensions



Capacité
Capacity



Référence
Reference



Conditionnement
Packaging

Assiettes - Esmeralda

ASSIETTE « TOKUDAÏ » ET « OOKI »



113201427



113201427



113211326



113211313



113201427COV



113201314COV

GRANDE ASSIETTE «TOKUDAÏ» 145x275 mm AVEC COUVERCLE

Large «TOKUDAÏ» plate
Plato grande «TOKUDAÏ»



145x275 mm
113201427
100



couvercle



-
113201427COV
200



PETITE ASSIETTE «TOKUDAÏ» 135x145 mm AVEC COUVERCLE

Small «TOKUDAÏ» plate
Plato pequeño «TOKUDAÏ»



135x145 mm
113201314/C
100



couvercle



135x145 mm
113201314COV/C
100



RAVIER «OOKI» PS 1/2 130x260 mm

«OOKI» 1/2 Dish
Ravier «OOKI» 1/2



130x260 mm
113211326
50



RAVIER «OOKI» PS 1/4 130x130 mm

«OOKI» 1/4 Dish
Ravier «OOKI» 1/4



130x130 mm
113211313
100



PLATEAU «TOKUDAÏ» / Réf. 09153011
«TOKUDAÏ» tray
Bandeja «TOKUDAÏ»



PLATEAU «OOKI» PS AVEC COUVERCLE APET
Réf. 09123827
«OOKI» tray
Bandeja «OOKI»



Dimensions
Dimensions



Capacité
Capacity



Référence
Reference



Conditionnement
Packaging

Assiettes - Frenchy folies

ASSIETTE « CARRÉ »



1412050



12115011



12115017

SALADIER «LUXE» TRANSPARENT PS 600CC

«LUXE» transparent salad bowl
Ensaladera «LUXE» transparente



base 100x100 mm

1412050

144 [12x12]



RAVIER CARRÉ TRANSPARENT PS

PS transparent square dish
Fuente cuadrada PS transparente



110x110x40 mm

12115011

288 [12x24]



ASSIETTE CARRÉE CREUSE TRANSPARENTE PS

PS transparent square shallow bowl
Plato hondo PS transparente



170x170x34 mm

12115017

192 [8x24]



Assiettes - Frenchy folies

ASSIETTE « EIGHTIE »

Fou des années 80 !



ASSIETTE «EIGHTIE» OCTOGONALE PS ROSE

*Pink octagonal «EIGHTIE» plate
Plato «EIGHTIE» octogonal rosa*

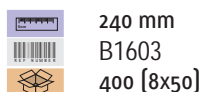
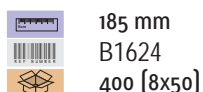

ASSIETTE «EIGHTIE» OCTOGONALE PS BLEUE

*Blue octagonal «EIGHTIE» plate
Plato «EIGHTIE» octogonal azul*

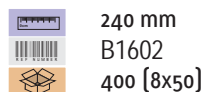
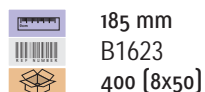

ASSIETTE «EIGHTIE» OCTOGONALE PS BLANCHE

*White octagonal «EIGHTIE» plate
Plato «EIGHTIE» octogonal blanco*

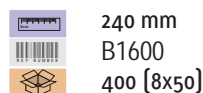
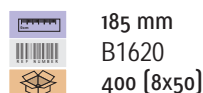

ASSIETTE «EIGHTIE» OCTOGONALE PS VERTE

*Green octagonal «EIGHTIE» plate
Plato «EIGHTIE» octogonal verde*

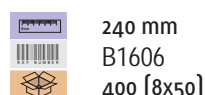
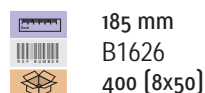

ASSIETTE «EIGHTIE» OCTOGONALE PS NOIRE

*Black octagonal «EIGHTIE» plate
Plato «EIGHTIE» octogonal negro*

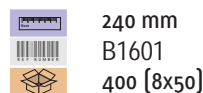
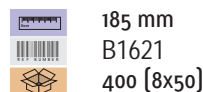

ASSIETTE «EIGHTIE» OCTOGONALE PS BORDEAUX

*Burgundy octagonal «EIGHTIE» plate
Plato «EIGHTIE» octogonal burdeos*

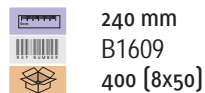
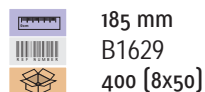

ASSIETTE «EIGHTIE» OCTOGONALE PS JAUNE

*Yellow octagonal «EIGHTIE» plate
Plato «EIGHTIE» octogonal amarillo*

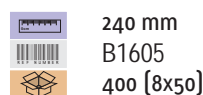
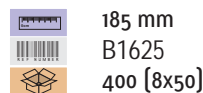

COUVERCLE PS TRANSPARENT POUR ASSIETTE «EIGHTIE»

*Transparent Lid for octagonal «EIGHTIE» plate
Tapa «EIGHTIE» transparente para plato octogonal*

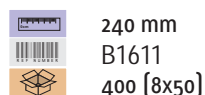
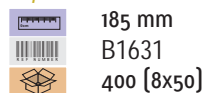

Assiettes

ASSIETTE COCKTAIL

ASSIETTE COCKTAIL PULP



1131020



1131020



1334025



1334025

ASSIETTE «COCKTAIL» + EMPLACEMENT VERRE OU FLÛTE

«COCKTAIL» plate with glass holder
Plato «COCKTAIL» con portava



200x200 mm
1131020
200 (10x20)



ASSIETTE «COCKTAIL» RONDE NOIRE

«COCKTAIL» black round plate
Plato «COCKTAIL» redondo negro
Couleur à partir de 3000 ex.



Ø 245 mm
1334025
48



ASSIETTE «COCKTAIL» PULPE CARRÉE + EMPLACEMENT VERRE OU FLÛTE

«COCKTAIL» square cellulose plate
Plato «COCKTAIL» cuadrado en pulpa



210x210 mm
1155121
300 (12x25)



ASSIETTE «COCKTAIL» PULPE CARRÉE + EMPLACEMENT VERRE OU FLÛTE

«COCKTAIL» square cellulose plate
Plato «COCKTAIL» cuadrado en pulpa



250x250 mm
1155125
300 (12x25)



Pour compléter ces plateaux, nous vous proposons :

FLÛTE «CRISTAL» PS POUR PLATEAU PRÉSENTATION 15 CL

PS «CRISTAL» flute for display tray
Copa de champán «CRISTAL» PS para bandeja



15 cl
8420151
200 (10x20)



VERRE «CRISTAL» PS POUR PLATEAU PRÉSENTATION 20 CL

PS «CRISTAL» glass for display tray
Vaso «CRISTAL» PS para bandeja



20 cl
8430031
200 (10x20)



Dimensions
Dimensions



Capacité
Capacity



Référence
Reference



Conditionnement
Packaging

Assiettes

Envie de folies ? Variez les plaisirs avec nos assiettes cocktails...

SALADIER WAN

PLAT OSARA

GAMME UENO

GAMME UENO -

GAMME UENO

GAMME UENO -



Ce plateau ne contient pas de verre



Ce plateau ne contient pas de verre



Ce plateau ne contient pas de couverts



Ce plateau ne contient pas de couverts

SOUS-ASSIETTE «WAN» PS 215x215 MM

«WAN» service plate
Bajoplato «WAN»

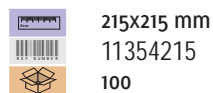

SOUS-ASSIETTE «OSARA» PS

«OSARA» Service Plate
Bajoplato Plat «OSARA»

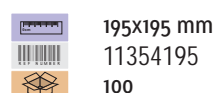

SALADIER «WAN» PS 200x200 MM

«WAN» Salad Bowl
Ensaladera «WAN»

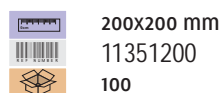

ASSIETTE PLAT «OSARA» PS

'OSARA' Plate
Plato Plat Osara

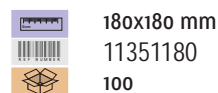

COUVERCLE «WAN» APET 215x215 MM

Lid for «WAN» Service Plate
Tapa para bajoplato «WAN»

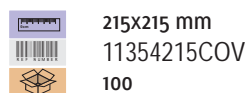

COUVERCLE «OSARA» APET

Cover for ueno «OSARA» service plate
tapa para bajoplato ueno plat osara

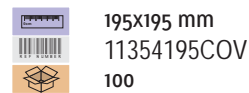

Assiettes - Wood Mood

ASSIETTE LUXE BOIS



BIO130180



BIO170170



BIO215085



BIO85155



BIO130180COV



BIO170170COV



BIO215085COV100





BIO85155COV

sur commande
to order / de encargo



ASSIETTE «LUXE» BOIS 130x180 MM

«LUXE» wooden small dish - Plato «Luxe» madera y tapa

 130x180 h28 mm
 BIO130180
 100



COUVERCLE / lid / Tapa



 -
 BIO130180COV
 100



sur commande
to order / de encargo



ASSIETTE «LUXE» BOIS 170x170 MM

«EIGHTIE» wooden plate - Plato «Luxe» madera y tapa

 170x170 h20 mm
 BIO170170
 100



COUVERCLE / lid / Tapa



 -
 BIO170170COV
 100



sur commande
to order / de encargo



RAVIER «LUXE» BOIS 215x85 MM

«EIGHTIE» wooden small dish - Plato «Luxe» madera y

 215x85 h28 mm
 BIO215085
 100



COUVERCLE / lid / Tapa



 -
 BIO215085COV
 100



sur commande
to order / de encargo



RAVIER «LUXE» BOIS 155x85 MM

«EIGHTIE» wooden plate - Plato «Luxe» madera y tapa

 155x85 h28 mm
 BIO85155
 100



COUVERCLE / lid / Tapa

 -
 BIO85155COV
 100



Retrouvez tous nos plateaux repas à partir de la page 51
et nos couverts «Wood Mood» p.131



Couverts «BOIS»

Wooden cutlery
Cubiertos de madera



Dimensions
Dimensions



Capacité
Capacity



Référence
Reference



Conditionnement
Packaging

Assiettes - Notre vision verte

ASSIETTE BOIS PEUPLIER



BIO116155/C

BIO116190/C1

BIO116215/C

BIO116225

BIO116260





BIO330195/C



BIO330265/C

ASSIETTE BOIS (PEUPLIER) RONDE Ø 150 mm



Round wooden plate
Plato de madera redondo

 155x10 mm
 BIO116155/C
 1200 [25x48]



ASSIETTE VAGUE BOIS



WAVE WOOD PLATE
PLATO DE MEDERA

 225X225 mm
 BIO116225
 800 [8x100]



ASSIETTE BOIS (PEUPLIER) RONDE Ø 190 mm



Round wooden plate
Plato de madera redondo

 190x15 mm
 BIO116190/C1
 600 [6x100]



ASSIETTE HEXAGONALE BOIS (PEUPLIER) Ø 260 mm



Hexagonal wooden plate Ø 10,2 inch
Plato de madera hexagonal

 Ø 260 mm
 BIO116260
 250



ASSIETTE BOIS (PEUPLIER) RONDE Ø 215 mm



Round wooden plate
Plato de madera redondo

 215x15 mm
 BIO116215/C
 600 [6x100]



ASSIETTE RECTANGULAIRE BOIS (PEUPLIER)



Rectangular wooden plate
Plato de madera rectangular

 195x140x30 mm
 BIO330195/C
 600 [6x100]



PLATEAU RECTANGULAIRE BOIS (PEUPLIER)

Rectangular wooden plate
Bandeja madera rectangular

 265x215x20 mm
 BIO330265/C
 250



Assiettes - Notre vision verte

ASSIETTE « PULPE »



1152117



1152121



1152125



32402015



1152117COV



1152121COV

Pulp instinct

**ASSIETTE PULPE CARREE 170 mm /
COUVERCLE RPET (PET RECYCLÉ)**
Square cellulose plate and RPET lid
Plato pulpa cuadrado/tapa PET reciclado

170x170 mm
 1152117
 300 [12x25]



180x180 mm
 1152117COV
 300 [6x50]



**ASSIETTE PULPE CARREE 210 mm /
COUVERCLE RPET (PET RECYCLÉ)**
Square cellulose plate 21cm and RPET lid
Plato pulpa cuadrado 21cm/tapa PET reciclado

210x210 mm
 1152121
 300 [12x25]



210x210 mm
 1152121COV
 300 [6x50]



BARQUETTE PULPE + COUVERCLE
Sugar cane pulp container with lid
Plato cuadrada pulpa y tapa

200x150x78 mm
 32402015
 500 [2x10x25]



ASSIETTE PULPE CARREE 250 mm
Square cellulose plate
Plato pulpa cuadrado

250x250 mm
 1152125
 300 [12x25]



Dimensions



Capacité
Capacity



Référence
Reference



Conditionnement
Packaging

Assiettes - Notre vision verte

ASSIETTE « PULPE » 



1151117/C2



1151126/3



1151122



1151126



1154132



1151123

ASSIETTE PULPE RONDE Ø 170 mm

Round Cellulose Plate
Plato pulpa redondo

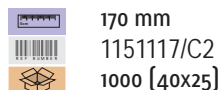

170 mm
1151117/C2
1000 [40x25]



ASSIETTE PULPE RONDE 3 COMPARTIMENTS Ø 260 mm

Round sugar cane pulp plate 3 compartments
Plato pulpa redondo 3 compartimentos



260 mm
1151126/3
500 [20x25]



ASSIETTE PULPE RONDE Ø 228,6 mm

Round Cellulose Plate
Plato pulpa redondo

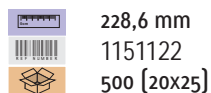

228,6 mm
1151122
500 [20x25]



ASSIETTE PULPE OVALE GRANDE

Large White oval cellulose plate
Plato pulpa ovalado grande



230x320 mm
1154132
500 [25x20]



ASSIETTE PULPE RONDE Ø 260 mm

Round Cellulose Plate
Plato pulpa redondo



260 mm
1151126
500 [20x25]



ASSIETTE PULPE OVALE MOYENNE

Medium white oval cellulose plate
Plato pulpa ovalado mediano



230x170 mm
1151123
600 [24x25]



Assiettes - Notre vision verte

ASSIETTE « PULPE »



14511500



145111000



115211326



14511500COV



115211326COV

SALADIER «PULPY RUGBY» Ensaladera «PULPY RUGBY»

700ml
 14511500
 500 (20x25)



1000 ml
 145111000
 200 (8x25)



COUVERCLE APET TRANSPARENT Tapa

14511500COV
 500 (20x25)



ASSIETTE PULPE RECTANGLE / COUVERCLE RPET (PET RECYCLÉ)

Rectangular cellulose plate and RPET lid
Plato pulpa rectangular/tapa PET reciclado

130x260 mm
 115211326
 300 (12x25)



145x275 mm
 115211326COV
 300 (6x50)



EMPILABLE
BELLE TRANSPARENCE DU COUVERCLE



Dimensions
Dimensions

Capacité
Capacity

Référence
Reference

Conditionnement
Packaging

Assiettes - Notre vision verte

ASSIETTE « COCKTAIL »





1155121



1155125

**ASSIETTE «COCKTAIL» PULPE CARRÉE
+ EMBLACEMENT VERRE A VIN OU FLÛTE**

«COCKTAIL» square cellulose plate
Plato «COCKTAIL» cuadrado en pulpa

 210x210 mm
 1155121
 300 (12x25)



**ASSIETTE «COCKTAIL» PULPE CARRÉE
+ EMBLACEMENT GOBELET**

«COCKTAIL» square cellulose plate
Plato «COCKTAIL» cuadrado en pulpa

 250x250 mm
 1155125
 300 (12x25)



Dimensions
Dimensions



Capacité
Capacity



Référence
Reference



Conditionnement
Packaging



100% DÉGRADABLE
100% COMPOSTABLE

mercredi 5 octobre 2016
Firplast a remporté
le Trophée Hopitech du
Développement Durable
pour sa barquette **100% bio.**



”

Le choix des produits et notre implication dans la recherche de matières biodégradables depuis de nombreuses années a permis de démarquer Firplast !



Dimensions
Dimensions



Capacité
Capacity



Référence
Reference



Conditionnement
Packaging

Saladiers et Mini-pots

Pot en APET
Saladier en APET et PS
Saladier Cristal White
Saladier Cristal Black
Bocal Terroir
Pot rond en PLA
Saladier Pulpy Rugby
Pot Pulpe
Boîte Sushi
Bol PP & saladier carton



Saladiers et mini-pots

POT EN PET



146008

146012

146016

146024

DM32

146006

146006

146006

146006

LG8

SALADIER ROND PET 24 CL - 8 OZ

Round PET salad bowl
Ensaladera redonda PET



24 cl - 8 oz
146008
500 (20x25)



COUVERCLE PET POUR SALADIER 146008, 146012, 146016, 146024

Lid for round PET salad bowl
Tapa para ensaladera redonda PET



-
146000
500 (20x25)



SALADIER ROND PET 34 CL - 12 OZ

Round PET salad bowl
Ensaladera redonda PET



34 cl - 12 oz
146012
500 (20x25)



SALADIER ROND PET 90 CL - 32 OZ

Round PET salad bowl
Ensaladera redonda PET



90 cl - 32 oz
DM32
500 (20x25)



SALADIER ROND PET 45 CL - 16 OZ

Round PET salad bowl
Ensaladera redonda PET



45 cl - 16 oz
146016
500 (20x25)



COUVERCLE PET POUR SALADIER DM32

Lid for round PET salad bowl
Tapa para ensaladera redonda PET



-
LG8
500 (20x25)



SALADIER ROND PET 68 CL - 24 OZ

PET round salad bowl
Ensaladera redonda PET



68 cl - 24 oz
146024
500 (20x25)



Dimensions
Dimensions



Capacité
Capacity



Référence
Reference



Conditionnement
Packaging

Saladiers et mini-pots : Envie de fraîcheur ?

SALADIER EN APET ET PS

Idéal pour la vente à emporter !



11350205



113201314



113201314



1464900



11350205COV



113201314



1464900COV2

GRANDE FAIM

SALADIER «SALADA» APET
«SALADA» salad bowl
Ensaladera «SALADA»



205x205 mm
11350205
100



COUVERCLE APET POUR SALADIER «SALADA»
Cover for «SALADA» salad bowl
Tapa para ensaladera «SALADA»



205x205 mm
11350205COV
100



ASSIETTE «SALADA» APET + COUVERCLE APET
«SALADA» plate
Plato «SALADA»



135x145 mm
113201314/C
100



«Grande faim» ou «Petite faim»,
vous n'arrivez pas à choisir ?
Optez pour le saladier «Vague» !

SALADIER «VAGUE» PS FOND TRANSPARENT + COUVERCLE
«VAGUE» salad bowl + transparent base + lid
Ensaladera «VAGUE» base transparente + tapa



175x175 mm
1131015
200 saladiers + 200 couvercles



PETITE FAIM

SALADIER «LUXE» TRANSPARENT PS
«LUXE» transparent salad bowl
Ensaladera «LUXE» transparente



base 100x100 mm
1412050
144 {12x12}



SALADIER BICOVER CARRÉ 900 CC AVEC COUVERCLE
Transparent bowl square transparent background + cover
Transparente square bowl + fondo transparente +
cubierta



191x191x58 mm
1464900
200



SUR COUVERCLE
Cover / Cubierta



165x155x24 mm
1464900COV2
200



pratique
pour les couverts



Saladiers et mini-pots

SALADIER CRISTAL WHITE



9825677/C



9825675/C1



9825622



9825645/C

SALADIER «CLASSIQUE CRISTAL» PET Ø 180 MM - H 70 MM
PET «CLASSIC CRISTAL» salad bowl
Ensaladera «CLASSIC CRISTAL» PET



Ø 180 mm - H 70 mm
 750 ml
 9825677/C
 200 (4x50)



SALADIER «CLASSIQUE CRISTAL» PET Ø 223 MM - H 91 MM
PET «CLASSIC CRISTAL» salad bowl
Ensaladera «CLASSIC CRISTAL» PET



Ø 260 mm - H 91 mm
 2400 ml
 9825622
 120 (1x120)



SALADIER «CLASSIQUE CRISTAL» PET Ø 162 MM - H 56 MM
PET «CLASSIC CRISTAL» salad bowl
Ensaladera «CLASSIC CRISTAL» PET



Ø 162 mm - H 56 mm
 1000 ml
 9825675/C1
 200 (4x50)



SALADIER «CLASSIQUE CRISTAL» PET Ø 310 MM
PET «CLASSIC CRISTAL» salad bowl
Ensaladera «CLASSIC CRISTAL» PET



Ø 310 mm
 4500 ml
 9825645/C
 50



Dimensions
 Dimensions



Capacité
 Capacity



Référence
 Reference



Conditionnement
 Packaging

Saladiers et mini-pots

SALADIER CRISTAL BLACK



9825375

9825322

9825345/C

9655411/C1

9655440

9655450/C

SALADIER «CLASSIQUE» PET NOIR Ø 180 MM

PET «CLASSIC» black salad bowl
Ensaladera PET negra «CLASSIC»

sur commande
to order / de encargo

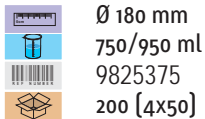

COUVERCLE «DÔME» PET POUR SALADIER «CLASSIQUE NOIR ET CRISTAL»

PET Lid for black and «CRISTAL» salad bowls
Tapa para ensaladera PET negra y «CRISTAL»

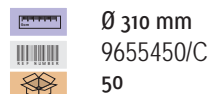
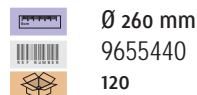
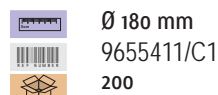

SALADIER «CLASSIQUE» PET NOIR Ø 260 MM

PET «CLASSIC» black salad bowl
Ensaladera PET negra «CLASSIC»



SALADIER «CLASSIQUE» PET NOIR Ø 310 MM

PET «CLASSIC» black salad bowl
Ensaladera PET negra «CLASSIC»

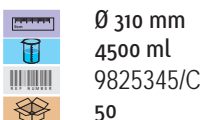

Saladiers et mini-pots

BOCAL « TERROIR »

Franchy folies



8470125



8470350





8470300



8470450



BOCAL «TERROIR» PLASTIQUE 125 ml
«TERROIR» container
Bocal «TERROIR»

 125 ml
 8470125
 84





BOCAL «TERROIR» PLASTIQUE 300 ml
«TERROIR» container
Bocal «TERROIR»

 300 ml
 8470300
 60 (10x6)





BOCAL «TERROIR» PLASTIQUE 350 ml
«TERROIR» container
Bocal «TERROIR»

 350 ml
 8470350
 48



BOCAL «TERROIR» PLASTIQUE 450 ml
«TERROIR» container
Bocal «TERROIR»

 450 ml
 8470450
 60 (10x6)



Saladiers et mini-pots

POT ROND EN PLA



Notre vision verte



BIO146024/C



BIO146016/C



BIO146012/C



BIO146000COV

POT ROND PLA 12OZ/300 ml

Round PLA container
Bote redondo PLA

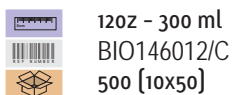

12oz - 300 ml
BIO146012/C
500 (10x50)



POT ROND PLA 24OZ/600 ml

Round PLA container
Bote redondo PLA

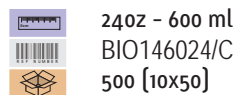

24oz - 600 ml
BIO146024/C
500 (10x50)



POT ROND PLA 16OZ/ 400 ml

Round PLA container
Bote redondo PLA

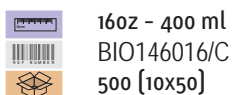

16oz - 400 ml
BIO146016/C
500 (10x50)



COUVERCLE PLA POUR POTS RONDS PLA 12/16/24 OZ

PLA Lid for round PLA containers
Tapa PLA para botes redondos PLA

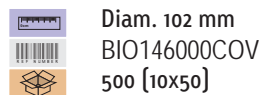

Diam. 102 mm
BIO146000COV
500 (10x50)

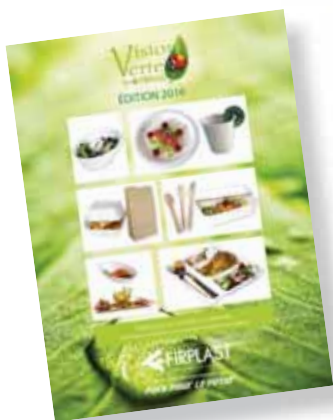

Demandez
notre nouveau
catalogue Vision verte

Saladiers et mini-pots

SALADIER « PULPY RUGBY »



Pulp instinct



14511500



145111000



145168/C



145130/C



145115



14511500COV



145168COV



145115COV

SALADIER «PULPY RUGBY» Ensaladera «PULPY RUGBY»

700 ml
 14511500
 500 (20x25)



1000 ml
 145111000
 200 (8x25)



COUVERCLE APET TRANSPARENT POUR SALADIER 700/1000 ML Tapa

14511500COV
 500 (20x25)



BOL PULPE CARRÉ 250 ml Square cellulose bowl Cuenco pulpa cuadrado

250 ml/15 oz-150x150mm
 145115
 300 (12x25)



COUVERCLE PET TRANSPARENT Tapa - Cover

145115COV
 300 (6x50)



BOL PULPE ROND 300 ml Round cellulose bowl Cuenco pulpa redondo

300 ml
 145130/C
 1800 (25x72)



BOL PULPE ROND 680 ml Round cellulose bowl Cuenco pulpa redondo

680 ml
 145168/C
 500 (20x25)



COUVERCLE Cover / Tapa

145168COV
 500 (10x50)



Dimensions
Dimensions



Capacité
Capacity



Référence
Reference



Conditionnement
Packaging

Saladiers et mini-pots

POT « PULPE »



145400



145105



BIO826140



BIO826200



8470350



BIO1360



145400COV



BIO13COV

MINI POT EN PULPE 57 ml

Cellulose mini-bowl
Minibote pulpa



57 ml - 2oz



145105



2000 (80x25)



MINI-POT «CRISTAL» PLA

«CRISTAL» mini-bowl - minibote «CRISTAL»



60 ml



BIO1360



2000 (20x100)



80 ml



BIO1380



2000 (20x100)



COUVERCLE PLA

Cover / Tapa



-



BIO13COV



2000 (20x100)



POT PULPE 140 ml

Cellulose bowl
Bote de pulpa



140 ml / 5 oz



BIO826140



1000 (40x25)



GOBELET PULPE 200/260 ml

Cellulose bowl
Bote de pulpa



200-260 ml / 9 oz



BIO826200



750 (30x25)



POT PULPE 425 ml

Cellulose bowl
Tapa pulpa



425 ml/15 oz



145400



1000 (40x25)



COUVERCLE PULPE

Lid for cellulose bowl
Tapa pulpa



-



145400COV



1000 (40x25)



Demandez
notre nouveau
catalogue Vision verte



Dimensions
Dimensions



Capacité
Capacity



Référence
Reference



Conditionnement
Packaging

Boîte Sushy

BOÎTE SUSHI



3050010



3050020/C



3050030/C



3050040/C



158000/C

BOITE SUSHI + COUVERCLE T. 1 PS

Sushi box size 1
Bandeja sushi medida 1



Boite

171x91x20 mm
3050010
600 [12x50]

Couvercle

176x96x30 mm
3050010COV
600 [12x50]

BOITE SUSHI + COUVERCLE T. 3 PS

Sushi box size 3
Bandeja sushi medida 3



Boite

185x129x20 mm
3050030/C
450 [9x50]

Couvercle

190x134x30 mm
3050030COV/C
450 [9x50]

BOITE SUSHI + COUVERCLE T. 2 PS

Sushi box size 2
Bandeja sushi medida 2



Boite

166x115x20 mm
3050020/C
300 [6x50]

Couvercle

171x120x30 mm
3050020COV/C
300 [6x50]

BOITE SUSHI + COUVERCLE T. 4 PS

Sushi box size 4
Bandeja sushi medida 4



Boite

215x135x20 mm
3050040/C
400 [8x50]

Couvercle

220x140x30 mm
3050040COV/C
400 [8x50]



Baguette chinoise en bois 20 cm

Wooden chopstick 20cm
Palillo de madera



200 mm
158000/C
3000 [30x100]



Dimensions
Dimensions



Capacité
Capacity



Référence
Reference



Conditionnement
Packaging

Saladiers et mini-pots

BOL PP & SALADIER CARTON



1439400



1430400COV



3050040/C



3132750



31321COV



31321COV

Idéal pour vos soupes et vos pâtes



BOL PP BLANC 400CC À FACETTE

Pp black 400cc Bol FACET
PP 400cc negro Bol FACETA

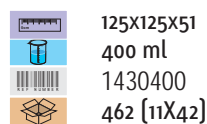

BOL PP NOIR 400CC À FACETTE

Pp black 400cc Bol FACET
PP 400cc negro Bol FACETA

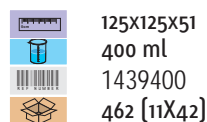

COUVERCLE PP POUR BOL FACETTES 1430400 ET 1439400

Pp cover for bowl and facets
PP cubierta para bowl y facetas

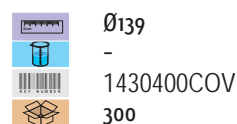

SALDIER CARTON PPT «VERT ANIS» ROND

Ø 150 MM - 100 CL X 360

Cardboard bowl PPT «LIME» ROUND Ø 150 MM

Tazón de cartón PPT REDONDO «CAL» Ø 150 MM

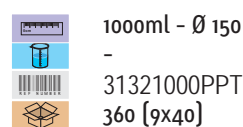

SALDIER CARTON PPT «BLANC» ROND

Ø 150 MM - 750 ML

Cardboard bowl PPT «LIME» ROUND Ø 150 MM

Tazón de cartón PPT REDONDO «CAL» Ø 150 MM

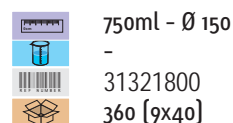

COUVERCLE SALDIER EN PLASTIQUE PET

Ø 150 MM - 100 CL X 360

Cardboard bowl PPT «LIME» ROUND Ø 150 MM

Tazón de cartón PPT REDONDO «CAL» Ø 150 MM

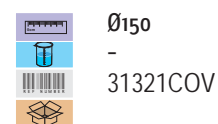

Saladiers et mini-pots

BOL PP & SALADIER CARTON



14625750



146257100COV



1462750COV1



146257100



14625750COV

SALADIER FOND CARRE APET TRANSPARENT SALADIER FOND CARRE APET TRANSPARENT CUENCO FONDO CUADRADO APET TRANSPARENTE

 160x160x75
 750CC
 14625750
 400 [4x100]







SALADIER FOND CARRE APET TRANSPARENT SALADIER FOND CARRE APET TRANSPARENT CUENCO FONDO CUADRADO APET TRANSPARENTE

 195x195x75
 1000CC
 146257100
 400 [4x100]







COUVERCLE DOME POUR SALADIER DOME COVER FOR SALAD CUBIERTA DEL DOMO PARA EL VASO

 160x160x20
 -
 14625750COV
 400 [4x100]





SALADIER FOND CARRE APET TRANSPARENT SALADIER FOND CARRE APET TRANSPARENT CUENCO FONDO CUADRADO APET TRANSPARENTE

 195x195x30
 -
 146257100COV
 400 [4x100]



COUVERCLE DOME POUR SALADIER DOME COVER FOR SALAD CUBIERTA DEL DOMO PARA EL VASO

 160x160x20
 -
 1462750COV1
 400 [4x100]



Dimensions
Dimensions



Capacité
Capacity



Référence
Reference



Conditionnement
Packaging

Coupes desserts

Coupe dessert ronde

Verre bodega

Coupe dessert «Esmeralda»

Coupe dessert en PET et PLA

Coupe dessert cristal



Coupes desserts

NOUVEAU

COUPE DESSERT RONDE



82400091



824000INS



82400091COV



COUPE DESSERT RONDE TRANSPARENT 30 CL

PET dessert cup

Copa de postre PET



30 cl



82400091



900



COUVERCLE PLAT TRANSPARENT POUR COUPE

82400091

Cover for cups 82400091

Tapa para copa 82400091



-



82400091COV



1800



COUPE INSERT TRANSPARENT POUR COUPES 82400091

PET dessert cup

Copa de postre PET



-



824000INS



2400



ELEMENTS
EMPILABLES

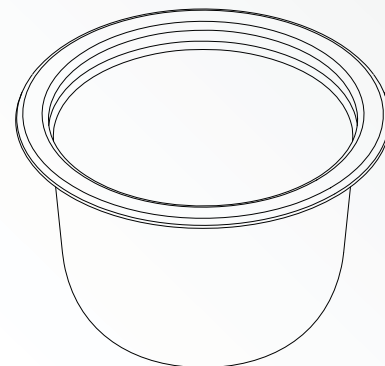
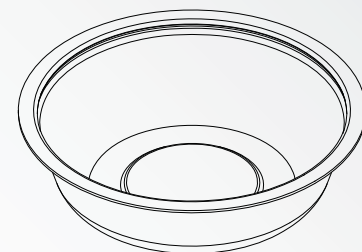
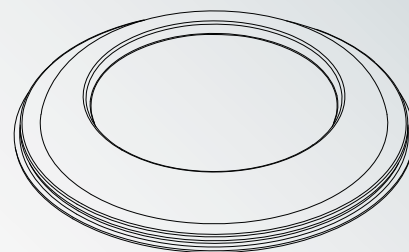

Dimensions
Dimensions



Capacité
Capacity



Référence
Reference



Conditionnement
Packaging

Coupes desserts

NOUVEAU

VERRE BODEGA



8430180



8430180COV



8430250



8430250COV

Verre bodega PS injecté 180 cc
Glass bodega PS injected 180cc
Cristal bodega PS inyectado 180cc



Couvercle verre bodega 180 cc
glass lid bodega 180cc
tapa de vidrio 180cc bodega



Verre bodega PS injecté 250 cc
Glass bodega PS injected 250cc
Cristal bodega PS inyectado 250cc

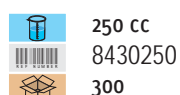

Couvercle verre bodega 180 cc
glass lid bodega 180cc
tapa de vidrio 180cc bodega

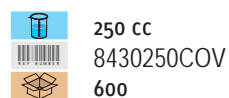

Coupes desserts

NOUVEAU

COUPE « ESMERALDA »



600021R



1410030



8240007



8240009



8084009

COUPE À DESSERT «ESMERALDA» VIOLETTE

«ESMERALDA» purple dessert cup
Copa de postre «ESMERALDA» lila



sur commande
to order / de encargo



COUPE A DESSERT PET 7 OZ / 20 CL

PET dessert cup
Copa de postre PET

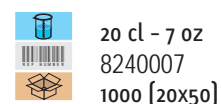

COUPE «LUXE» PS

«LUXE» PS cup
Copa de postre «LUXE» PS



COUPE À DESSERT PET 9 OZ / 27 CL

PET dessert cup
Copa de postre PET



COUVERCLE PLAT SANS TROU POUR COUPE

8240009 / 8240007
Cover for cups 8240009 / 8240007
Tapa para copa 8240009 / 8240007



Dimensions
Dimensions



Capacité
Capacity



Référence
Reference



Conditionnement
Packaging

Coupes desserts

COUPE À DESSERT PLA



BIO14080



BIO14170



GK1331PP



8240105



BIO15095



MK1619



8080105

COUPE À DESSERT PLA BLANC TRANSPARENT 8 CL

Transparent white PLA dessert cup
Copa de postre PLA blanca

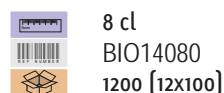

8 cl

BIO14080

1200 (12x100)



sur commande
to order / de encargo

COUPE À DESSERT PP 15 CL

PP dessert cup
Copa de postre PP



15 CL

GK1331PP

600 (24x25)



COUPE À DESSERT PLA BLANC TRANSPARENT 21 CL

Transparent white PLA dessert cup
Copa de postre PLA blanca



21 cl

BIO14170

800 (8x100)



sur commande
to order / de encargo

COUVERCLE

Cover - Tapa



MK1619

600 (12x50)



CUILLÈRE DESSERT COULEURS VARIÉES VERT ET BLANC

Pla dessert spoon, green and white assortment
Cuchara de postre pla verde y blanca

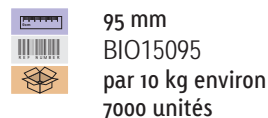

95 mm

BIO15095

par 10 kg environ
7000 unités



sur commande
to order / de encargo

COUPE À DESSERT «CRISTAL» APET 25/30 CL

APET «CRISTAL» dessert cup
Copa de postre «CRISTAL» APET

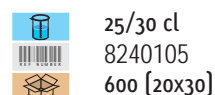

25/30 cl

8240105

600 (20x30)



COUVERCLE PLAT

Cover - Tapa



8080105

600 (20x30)



Capacité
Capacity



Référence
Reference



Conditionnement
Packaging



Couverts sachets couverts et accessoires

Collection luxe transparent - noir - argent - inox

Sachet couvert 2/1 - 3/1 - 6/1

Sachet couvert éco

Couvert à dessert

Collection Vision Verte

Collection «Wood Mood»

Collection «Franchy folies»

Etui couverts

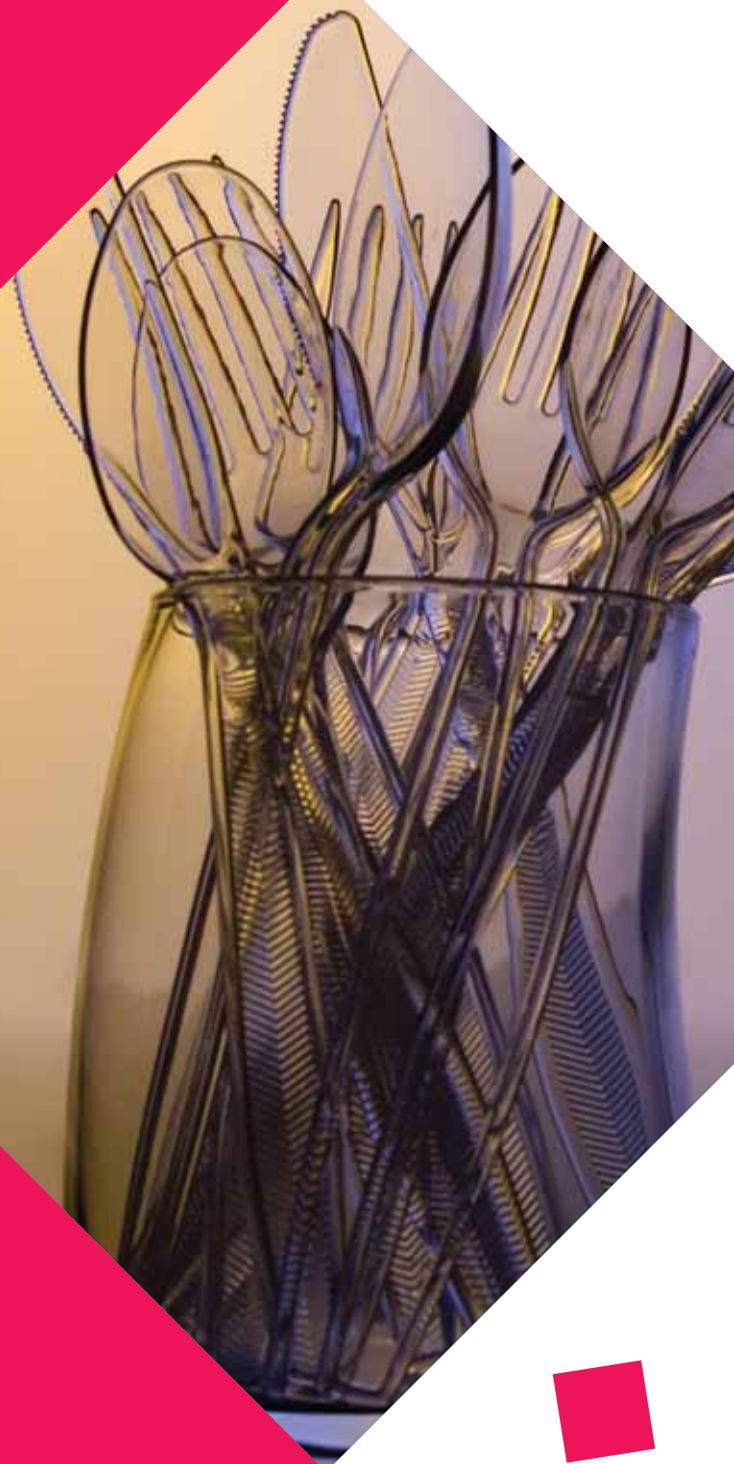

Couverts, sachets couverts et accessoires

Collection «LUXE» transparent

FOURCHETTE PS TRANSPARENT

PS transparent fork / Tenedor PS transparente

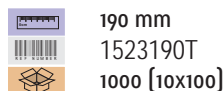

COUTEAU PS TRANSPARENT

PS transparent knife / Cuchillo PS transparente

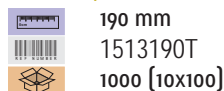

CUILLÈRE ENTREMET PS TRANSPARENT

PS transparent spoon / Cuchara PS transparente

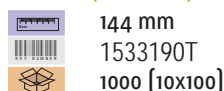

CUILLÈRE À DESSERT PS TRANSPARENT

PS transparent dessert spoon / Cuchara de postre PS transparente

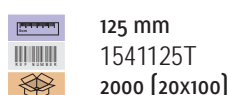

FOURCHETTE TRANSPARENTE «GIVRÉE» PS

PS «GIVRÉE» transparent fork

Tenedor «GIVRÉE» PS transparente



COUTEAU TRANSPARENTE «GIVRÉE» PS

PS «GIVRÉE» transparent knife

Cuchillo «GIVRÉE» PS transparente



CUILLÈRE TRANSPARENTE «GIVRÉE» PS

PS «GIVRÉE» transparent spoon

Cuchara «GIVRÉE» PS transparente



CUILLÈRE DESSERT LUXE TRANSPARENTE «GIVRÉE» 128 MM PS

PS «GIVRÉE» transparent spoon

Cuchara «GIVRÉE» PS transparente



Couverts, sachets couverts et accessoires

Pour compléter nos verrines éphémères, nous vous proposons les couverts suivants :

FOURCHETTE «COCKTAIL» PS TRANSPARENT

PS transparent cocktail fork
Minitenedor PS transparente

 100 mm
 1513103
 1000 [25x40]



CUILLÈRE «COCKTAIL» PS TRANSPARENT



PS transparent cocktail spoon
Minicuchara PS transparente

 100 mm
 1543103
 1000 [25x40]



FOURCHETTE «COCKTAIL ARGENT» PS

PS transparent «COCKTAIL» fork
Minitenedor plateado «COCKTAIL» PS

 100 mm
 1513104
 1920 [48x40]



CUILLÈRE «COCKTAIL ARGENT» PS

PS transparent «COCKTAIL» spoon
Minicuchara plateada «COCKTAIL» PS



 100 mm
 1543104
 1920 [48x40]



Collection «LUXE» noir



FOURCHETTE PS NOIR

PS black fork
Tenedor PS negro

 190 mm
 1523190N/C
 1000 [10x100]



CUILLÈRE À DESSERT PS NOIR

PS black dessert spoon
Cuchara de postre PS negra

 125 mm
 1543125N
 1500 [3x500]

COUTEAU PS NOIR

PS black knife
Cuchillo PS negro

 190 mm
 1513190NC
 1000 [10x100]



Collection «LUXE» argent



FOURCHETTE ARGENT PS

PS silver fork
Tenedor PS plateado

 188 mm
 1513419
 1000 [50x20]

CUILLÈRE SOUPE 175 MM

Soup spoon 175 MM
Cuchara cene 175 mm

 175 mm
 1533418
 1000 [50x20]

COUTEAU ARGENT PS

PS silver knife
Cuchillo PS plateado

 200 mm
 1523420
 1000 [50x20]

CUILLÈRE DESSERT 130 MM

Dessert spoon 130 MM
Cuchara de postre 130 MM

 130 mm
 1533413
 1000 [50x20]



Sachets couverts

Collection «LUXE» inox



1500633AR/C

SACHETS COUVERTS LUXE 2/1



1506121LT

Kit 4/1 INOX RÉUTILISABLE :

FOURCHETTE+COUTEAU+ CUILLERE+SERVIETTE

Kit 4/1 INOX REUSABLE: FORK SPOON KNIFE + towel

Kit 4/1 INOX reutilizable : TENEDOR cuchara del cuchillo + toalla



-
1500633AR/C
250



SACHET LUXE 2/1 TRANSPARENT : FOURCHETTE PS + COUTEAU PS

Transparent cutlery sachet 2/1 : PS fork + PS knife

Bolsita cubiertos transparentes 2 en 1 : tenedor PS + cuchillo PS



-
1506121LT
250



Dimensions
Dimensions



Capacité
Capacity



Référence
Reference



Conditionnement
Packaging

Couverts, sachets couverts et accessoires

SACHETS COUVERTS LUXE 3/1

SACHETS COUVERTS LUXE 6/1

1 Solution tout en un 2, 3, 4, 6 ? Suivez le guide...



1506131LT



1500633LT



1500661

SACHET COUVERT 3/1 TRANSPARENT : COUTEAU + FOURCHETTE + SERVIETTE

Bag cover 3/1 transparent : knife and fork + towel
Bolsita cubiertos transparentes 3 en 1 : tenedor + cuchillo + toalla

 250x45
 1500631LT
 250



SACHET COUVERT 6/1 TRANSPARENT : COUTEAU + FOURCHETTE + PETITE CUILLERE + SERVIETTE + SEL + POIVRE



Bag cover 3/1 transparent : knife and fork + towel
Bolsita cubiertos transparentes 3 en 1 : tenedor + cuchillo + toalla

 250x45
 1500661
 250



SACHET LUXE 3/1 TRANSPARENT : FOURCHETTE PS + COUTEAU PS + CUILLÈRE PS

3-In-1 pack of transparent cutlery : PS fork + PS knife
+ PS spoon / Bolsita cubiertos transparentes 3 en 1 :
tenedor PS + cuchillo PS

 -
 1500633LT
 250



Couverts, sachets couverts et accessoires

Collection «ECO»



1500650



1500631



1500632



1500640



1500660

SACHET ECO 3/1 : couteau + petite cuillère + serviette

Eco bag 3/1: knife + spoon and napkin
Eco bag 3/1: Cuchillo + cuchara y servilleta



170 mm
1500631LT
250



SACHET ECO 5/1 : couteau + fourchette + petite cuillère + serviette

ECO BAG 5/1: knife + fork + spoon and napkin
[tenedor + cuchillo + cuchara de postre + servilleta]



170 mm
1500650
250



SACHET COUVERT 3/1 : couteau + cuillère à soupe + serviette

BAG COVER 3/1: knife + spoon and napkin
Bolso de la cubierta 3/1: Cuchillo + cuchara y servilleta



170 mm
1500632
250

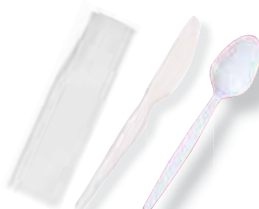

SACHET 6/1 BLANC (FOURCHETTE PS + COUPEAU PS + PETITE CUILLÈRE PS + SERVIETTE + POIVRE & SEL)

6-In-1 pack of white cutlery
[fork + knife + dessert spoon + serviette + salt & pepper]
Bolsita cubiertos blancos 6 en 1
[tenedor + cuchillo + cuchara de postre + servilleta + sal y pimienta]



—
1500660
250



SACHET COUVERT 4/1 : couteau + fourchette + cuillère + serviette

BAG COVER 4/1: Knife + Fork + Spoon + towel
Bolso de la cubierta 4/1: Cuchillo + Tenedor + cuchara + toalla



170 mm
1500640
250



Dimensions
Dimensions



Capacité
Capacity



Référence
Reference



Conditionnement
Packaging

Sachets couverts

Collection «ECO»



1500633LT



1500633LT



1506100



1500210

SACHET ECO 1/1 : CUILLÈRE PS TRANSPARENT 125 MM

Individually wrapped : PS transparent spoon

Bolsita cubiertos : cuchara PS transparente



125 mm

1500610T

1000



SACHET ECO 2/1 : PETITE CUILLÈRE PS 125 MM + SERVIETTE

2-In-1 pack of cutlery : small PS spoon + serviette

Bolsita cubiertos 2 en 1 : cucharilla PS + servilleta



-

1500210

500



SACHET ECO 2/1 BLANC : FOURCHETTE PS + COUPEAU PS

2-In-1 pack of white cutlery : PS fork + PS knife

Bolsita cubiertos blancos 2 en 1 : tenedor PS + cuchillo PS



-

1506100

500



SACHET ECO 3/1 BLANC : FOURCHETTE PS + COUPEAU PS + SERVIETTE

3-In-1 pack of white cutlery : PS fork + PS knife + PS serviette

Bolsita cubiertos blancos 3 en 1 : tenedor PS + cuchillo PS+ Servilleta



-

1500630

250

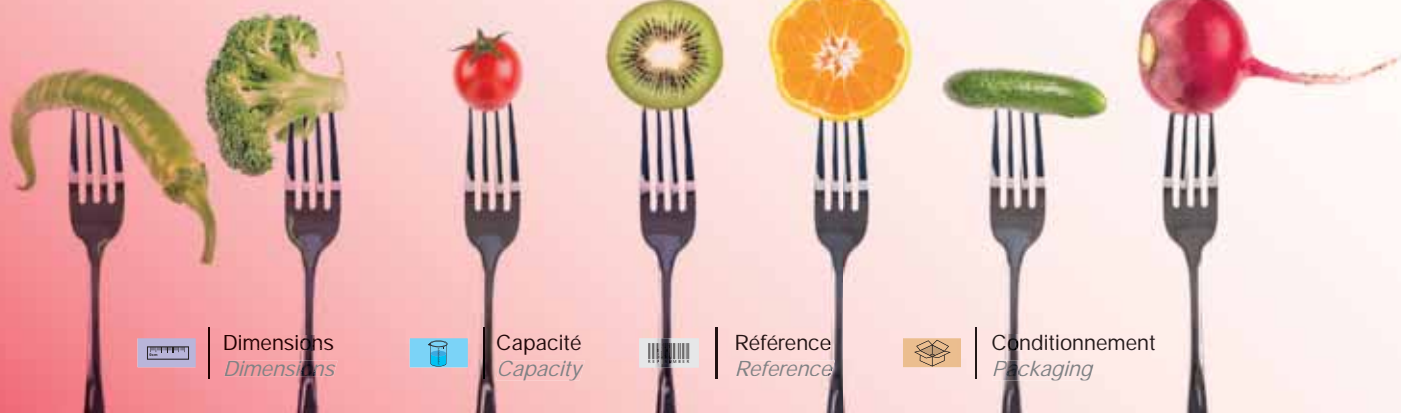

Dimensions
Dimensions



Capacité
Capacity



Référence
Reference



Conditionnement
Packaging

Sachets couverts

Collection «Wood Mood»



SACHET 3/1 BOIS (COUPEAU + FOURCHETTE + CUILLIÈRE)

3-in-1 pack of wooden cutlery [fork + knife + spoon]
Bolsita de cubiertos 3 en 1 madera [cuchillo + tenedor + cuchara]

 165 mm
 1590630
 300

Vision
Verte
by 





Collection «Vision Verte»



SACHET 3/1 AMIDON DE MAÏS (COUPEAU + FOURCHETTE + SERVIETTE)

3-In-1 pack of cellulose cutlery [fork + knife + serviette]
Bolsa de cubiertos de madera [cuchillo + tenedor + servilleta]

 270x75x15 mm
 BIO1500630
 500





Collection «Vision Verte»



CUILLIÈRE DESSERT COULEURS VERT ET BLANC

Dessert spoon colors green and white
Cuchara de postre PLA verde y blanca

sur commande
to order / de encargo

 95 mm
 BIO15095
 10 kg soit 7000 unités environ



Dimensions
Dimensions



Capacité
Capacity



Référence
Reference



Conditionnement
Packaging

Couverts, sachets couverts et accessoires

Collection «Vision Verte»



FOURCHETTE AMIDON DE MAÏS

Corn starch fork
Tenedor almidón de maíz

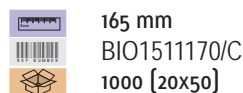

CUILLERE AMIDON DE MAÏS

Corn starch spoon
Cuchara almidón de maíz

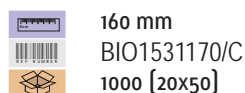

COUTEAU AMIDON DE MAÏS

Corn starch knife
Cuchillo almidón de maíz

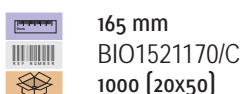

CUILLÈRE À DESSERT BIODÉGRADABLE 120 MM IVOIRE

Dessert spoon biodegradable 120mm ivory
Cuchara de postre biodegradables de 120 mm de marfil

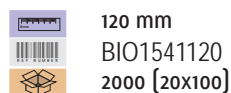

SACHET COUVERTS 3 EN 1 LUXE BIODÉGRADABLE (COUTEAU+FOURCHETTE+SERVIETTE) AMIDON DE MAÏS

3 in 1 bag covered biodegradable luxury (KNIFE AND FORK + TOWEL) CORN STARCH
3 en 1 bolso de lujo cubiertos biodegradables (CUCHILLO Y TENEDOR + toalla) ALMIDÓN DE MAÍZ

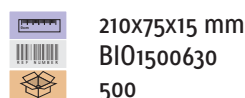

SACHET 4/1 ABDP (COUTEAU+FOURCHETTE+CUILLÈRE+SERVIETTE)

Bag 4/1 ABDP (knives and fork + Spoon + TOWEL)
Bolsa de cubiertos de madera [cuchillo+tenedor +CUCHARA +servilleta]

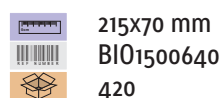

Couverts, sachets couverts et accessoires

Collection «Wood Mood»



FOURCHETTE BOIS

Wooden fork
Tenedor de madera

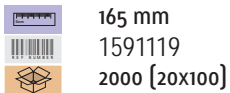

COUPEAU BOIS

Wooden knife
Cuchillo de madera

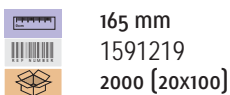

CUILLERE A SOUPE BOIS

Wooden soup spoon
Cuchara de madera

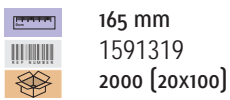

CUILLERE À DESSERT BOIS

Wooden dessert spoon
Cuchara de postre madera

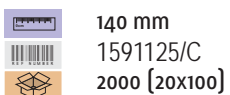

CUILLERE À CAFE BOIS

Wooden coffee spoon
Cucharilla de café madera

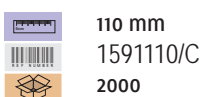

1591119



1591219



1590632



1591319



1591125/C



1591110/C

KIT BOIS 3/1

couteau + fourchette + cuillère
KIT WOOD 3/1 - Knife + fork + spoon
KIT 3/1 MADERA -
Cuchillo + Tenedor + cuchara

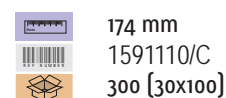

Pour compléter cette gamme,
nous vous proposons le sachet couvert :

SACHET 3/1 BIODÉGRADABLE
(COUPEAU + FOURCHETTE + SERVIETTE)
(Réf. BIO1500630) Page 113



Pour compléter cette gamme, nous vous
proposons le sachet couvert :

SACHET 3/1 BOIS (COUPEAU + FOURCHETTE + CUILLÈRE)
(Réf. 1590630) Page 113



Dimensions
Dimensions



Capacité
Capacity



Référence
Reference



Conditionnement
Packaging

Couverts, sachets couverts et accessoires

COUVERTS À DESSERTS

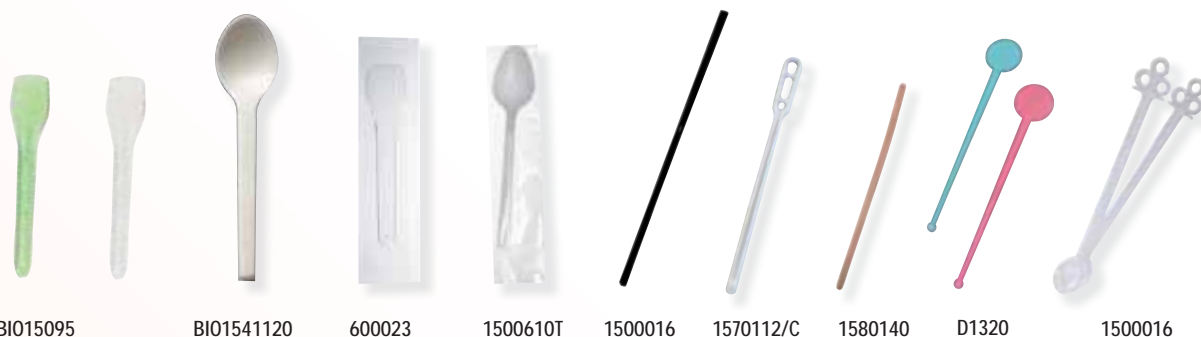

BIO15095

BIO1541120

600023

1500610T

1500016

1570112/C

1580140

D1320

1500016

CUILLÈRE DESSERT COULEURS VARIÉES VERT ET BLANC

Pla dessert spoon, green and white assortment
Cuchara de postre pla verde y blanca

95 mm
BIO15095
10 kg soit environ
7000 unités



sur commande
to order / de encargo

SPATULE CAFÉ PLASTIQUE BLANC

White plastic coffee stirrer
Espátula café plástico blanco

112 mm
1570112/C
5000 [5x1000]



CUILLÈRE DESSERT BIODÉGRADABLE PLA

PLA biodegradable dessert spoon
Cuchara PLA

120 mm
BIO1541120
2000 [20x100]



SPATULE CAFÉ BOIS

Wooden coffee stirrer
Espátula café madera

140 mm
1580140
10000 [10x1000]



CUILLÈRE À GLACE EMBALLÉE

Individually wrapped ice cream spoon
Cuchara de postre envasada

—
600023
5000



AGITATEUR MULTICOLORE

Coloured swizzle stick
Removedor multicolor

170 mm
D1320
2000 [20x100]

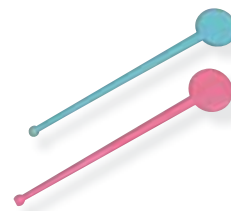

SACHET COUVERT : CUILLÈRE TRANSPARENTE 125 MM

Individually wrapped : transparent spoon
Bolsita cubiertos : cuchara transparente

125 mm
1500610T
1000



AGITATEUR CUILLÈRE TRANSPARENT

Transparent swizzle stick
Cuchara removedora transparente

178 mm
1500016
2000 [20x100]



PAILLE MOJITO NOIRE

Mojito black straw
Paja negro mojito

178 mm
1500016
2000 [20x100]

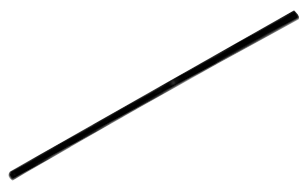

Dimensions
Dimensions



Capacité
Capacity



Référence
Reference



Conditionnement
Packaging

Couverts, sachets couverts et accessoires

Collection «Wood Mood»

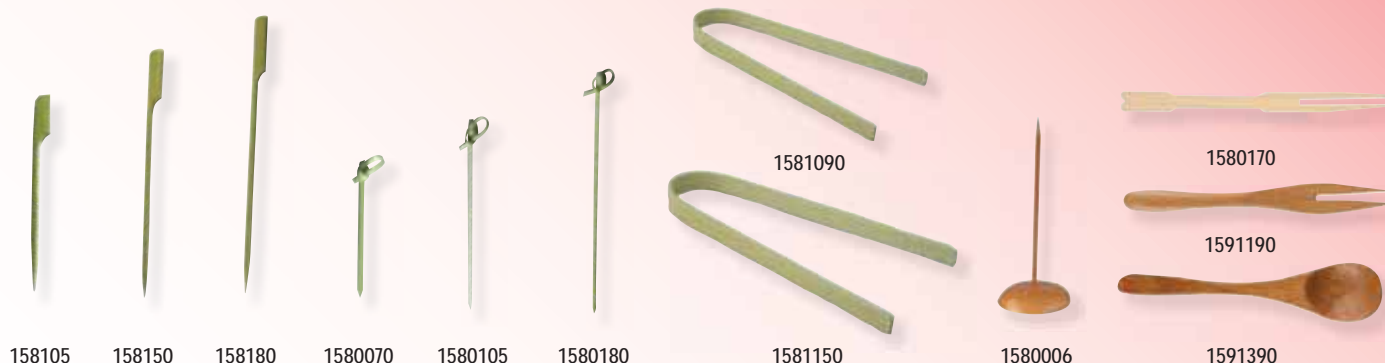

PINCE BAMBOU 90 mm

Bamboo tongs
Pinza bambú

90 mm
 1581090
 2000 [20x100]



PINCE BAMBOU 150 mm

Bamboo tongs
Pinza bambú

150 mm
 1581150
 200 [10x20]



sur commande
to order / de encargo

PIQUE DRAPEAU BAMBOU

Bamboo flag appetiser pick
Palillo extremo plano bambú

105 mm
 158105
 2000 [20x100]

150 mm
 158150
 2000 [20x100]

180 mm
 158180
 2000 [20x100]

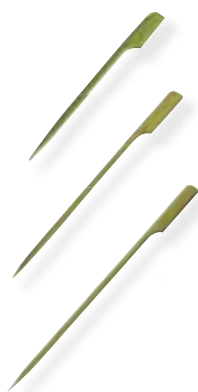

PIQUE BAMBOU FOURCHETTE

Bamboo cocktail fork
Palillo con tenedor bambú

90 mm
 1580170
 2000 [20x100]



PIC SUR PIED BAMBOU

Bamboo skewer with stand
Pincho con base bambú

90 mm
 1580006
 240 [10x24]



PIQUE NOEUD BAMBOU

Bamboo knot appetiser pick
Palillo nudo bambú

70 mm
 1580070
 2000 [20x100]

100 mm
 1580105
 2000 [20x100]

180 mm
 1580180
 2000 [20x100]



FOURCHETTE BAMBOU

Bamboo fork
Tenedor bambú

90 mm
 1591190
 480 [20x24]



CUILLÈRE BAMBOU

Bamboo spoon
Cuchara bambú

90 mm
 1591390
 480 [20x24]



Dimensions
Dimensions



Capacité
Capacity



Référence
Reference



Conditionnement
Packaging

Couverts, sachets couverts et accessoires

Collection «Wood Mood»



WT108

WT106

1580140

1580110

158000/C

WT521

WT100

WT104

WT102

PIQUE «COCKTAIL» BOIS

Wooden «COCKTAIL» pick
Palillo «COCKTAIL» madera



CURE-DENTS BOIS ENVELOPPÉS INDIVIDUELLEMENT

Individually wrapped wooden toothpicks
Mondadientes envase individual



PIQUE «COCKTAIL» 2 POINTES BOIS

Wooden «COCKTAIL» pick
Palillo «COCKTAIL» madera

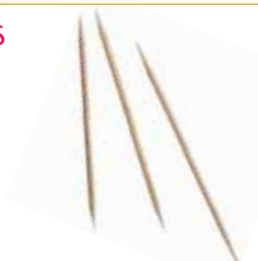

BROCHETTE BOIS 150 MM

Wooden skewer
Pincho de madera



AGITATEUR CAFE BOIS 140 MM

Wooden coffee stirrer
Removedor para café madera

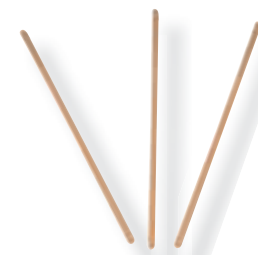
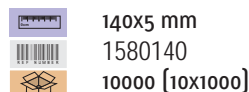

BROCHETTE BOIS 200 MM

Wooden skewer
Pincho de madera



AGITATEUR CAFE BOIS 110 MM

Wooden coffee stirrer
Removedor para café madera

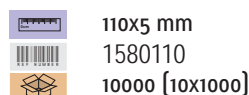

BROCHETTE BOIS 300 MM

Wooden skewer
Pincho de madera



BAGUETTES CHINOISE BOIS ENVELOPPÉES

Wooden chopsticks in envelope
Palillos chinos madera

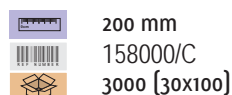

Couverts, sachets couverts et accessoires

PIQUE BAMBOU BOUCLE

Bamboo fork
Tenedor bambú

90 mm
1582120
480 [20x24]



1582120
1582120
1582120

1583120

1584120

PIQUE BAMBOU BOUCLE

Bamboo fork
Tenedor bambú

90 mm
1583120
480 [20x24]



PIQUE BAMBOU BOULE COULEUR

Bamboo pic

90 mm
1583120
480 [20x24]



PIQUE BAMBOU BOUCLE

Bamboo fork
Tenedor bambú

90 mm
158290
480 [20x24]



PIQUE BAMBOU BOULE NATUREL

Bamboo pic

90 mm
1584120
480 [20x24]



Collection «Frenchy folies»

RINCE-DOIGTS

Finger wipes
Toallita limpiadora

—
10001
1000

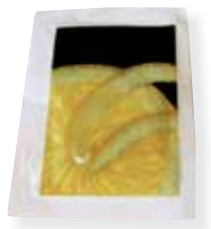

SEL & POIVRE

Salt & pepper
Sal y pimienta

—
DUO/C
220



PIPETTE À SAUCE

Pipette for sauce
Pipeta para salsa

4 ml
00000000PS01
12



ETUI COUVERT

ETUI COUVERT BRUN «BON APPÉTIT»

+SERVIETTE PASTEL 2PLIS 23X39
Brown «BON APPÉTIT» cutlery case
+ pastel serviette 23x39
Estuche para cubiertos «BON APPÉTIT» marrón
+ servilleta pastel 23x39

200x85 mm
0900302
600



personnalisable

Exemples de personnalisation
Examples of customisation - Ejemplos de personalización



Dimensions
Dimensions



Capacité
Capacity



Référence
Reference



Conditionnement
Packaging

Verres Nect'Art

Envie de champagne
Collection Nect'art
Verre à pied et dégustation
Pause café
Verre collector «Ballon de rugby»
Verre réutilisable
Verre en Tritan
Bouteilles



Liquide

COLLECTION « FLÛTE @ COUPE »



8420220/C



CHAMPM3



8410006



8230320

FLUTE CHAMPAGNE PS TRANSP. 10/12 CL MONOBLOC

*PS transparent champagne flute
Copa de champán PS transparente*



10-12 cl
8420220/C
200 [20x10]



FLUTE CHAMPAGNE PS TRANSP. 7-5 CL MONOBLOC

*PS transparent champagne flute
Copa de champán PS transparente*



7-5 cl
CHAMPM3
160 [16x10]



VERRE À COCKTAIL PS LIGNÉ 10 CL PIED AMOVIBLE

*Transparent cocktail glass
Copa de cóctel transparente 2 piezas*



10/16 cl
8410006
240 [12x20]



VERRE «LONG DRINK» PS

*PS «LONG DRINK» glass
Vaso «LONG DRINK» PS*



32 cl
8230320
500 [10x50]



Dimensions
Dimensions



Capacité
Capacity



Référence
Reference



Conditionnement
Packaging

Verres et supports

COLLECTION «VERRE CONIQUE»



842012N



0915016



0915017

VERRE CONIQUE «KEOPS» PS

PS «KEOPS» cone-shaped glass - Vaso «KEOPS» cónico PS



noir/black/negro
Ø 6 cm - h 17 cm
12 cl
842012N
20

sur commande
to order / de encargo



blanc/white/blanco
Ø 6 cm - h 17 cm
12 cl
842012B
20



transparent
Ø 6 cm - h 17 cm
12 cl
842012T
20



PORTE-VERRES 3 «KEOPS» PS

PS holder for 3 «KEOPS» glasses
Portavasos para 3 «KEOPS» PS



15x15 cm - h 24,5 cm
0915016
6

sur commande
to order / de encargo



PORTE-VERRES 11 «KEOPS» PS

PS holder for 11 «KEOPS» glasses
Portavasos para 11 «KEOPS» PS



20x8,5 cm - h 24,5 cm
0915017
1

sur commande
to order / de encargo



Dimensions
Dimensiones



Capacité
Capacity



Référence
Referencia



Quantité
Cantidad



Image
Imagen

Liquide

Collection « VERRE CRISTAL »



7023



8430031



8420151



0915035

VERRE «CRISTAL» OCTOGONAL PS 25 CL

PS octagonal «CRISTAL» glass

Vaso «CRISTAL» PS



25 cl
7023
1000 (40x25)



VERRE «CRISTAL» PS POUR PLATEAU PRÉSENTATION 20 CL

PS «CRISTAL» glass for display tray

Vaso «CRISTAL» PS para bandeja



20 cl
8430031
200 (10x20)



PLATEAU PRÉSENTATION 20 VERRES/FLÛTES PS

PS display tray for 20 glasses/flutes

Bandeja para 20 vasos/copas de champán PS



360x255x60 mm
0915035
60 (10x6)



FLÛTE «CRISTAL» PS POUR PLATEAU PRÉSENTATION 15 CL

PS «CRISTAL» flute for display tray

Copa de champán «CRISTAL» PS para bandeja



15 cl
8420151
200 (10x20)



Dimensions
Dimensions



Capacité
Capacity



Référence
Reference



Conditionnement
Packaging

Liquide

Collection « VERRE À VIN »



GK10

GK20



E192/C



82211000



8430210

VERRE À VIN PS 10 CL

PS wine glass
Copa de vino PS

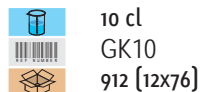

VERRE À DÉGUSTATION PS 7 CL

PS degustation glass
Vaso degustación PS

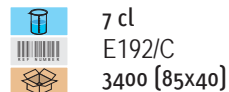

VERRE À VIN PS 17 CL

PS wine glass
Copa de vino PS



VERRE À DÉGUSTATION PS 10 CL

PS degustation glass
Vaso degustación PS



VERRE BODEGA 21 CL

PS bodega glass
Vaso bodega PS

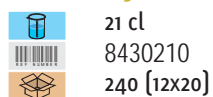

Verre Bodega existe
aussi en verre



Dimensions
Dimensions



Capacité
Capacity



Référence
Reference



Conditionnement
Packaging

Gobelet carton havane

Pause café

Utilisation froide ou chaude



8000178



8000182



8000179/C



10LGC4S/C



10LGC4S/C



10LGC10S

GOBELET CARTON KRAFT BRUN 10 CL



Cup brown kraft cardboard
Copa de cartón kraft marrón

 10 cl / 4 OZ
 8000178
 3000



COUVERCLE BLANC DOME



White dome lid
Tapa blanco

 4 OZ
 10LGC4
 3000 [30x100]



COUVERCLE BLANC PLAT

Flat white lid
Tapa blanca plana

 4 OZ
 10LGC4S/C
 1000



GOBELET CARTON KRAFT BRUN 18 CL

Cup brown kraft cardboard
Copa de cartón kraft marrón

 18 cl / 6 OZ
 8000182
 1500



COUVERCLE BLANC PLAT



Flat white lid
Tapa blanca plana

 6 OZ
 10LGC6B
 1000 [10X100]



COUVERCLE BLANC DOME



White dome lid
Tapa blanco

 6 OZ
 10LGC6
 2000 [20X100]



GOBELET CARTON KRAFT BRUN 25/30 CL

Cup brown kraft cardboard
Copa de cartón kraft marrón

 25 /30 cl - 10 OZ
 8000179/C
 1500



COUVERCLE BLANC DOME

White dome lid
Tapa blanco

 10 OZ
 10LGC10S
 1000 [10X100]



Dimensions
Dimensions



Capacité
Capacity



Référence
Reference



Conditionnement
Packaging

Gobelet bio

nouveau

Pause café

Utilisation froide ou chaude



BIO800100/C



BIO800200



BIO8008200



1580110



1580140

GOBELET CARTON/PLA 10 CL

Cardboard cup / PLA 10cl
Vaso de cartón / 10cl PLA



10 cl / 4 OZ
BIO800100PPT
3000



COUVERCLE BLANC CPLA

White lid CPLA
Tapa CPLA



-
BIO808100
1000 (10x100)



sur commande
to order / de encargo

SPATULE BOIS

BIO spatula
Espátula BIO



110x5 mm
1580110
10000 (10x1000)



140x5 mm
1580140
10000 (10x1000)



GOBELET CARTON/PLA 20/30 CL

Cardboard cup / PLA 20cl
Vaso de cartón / 20cl PLA



20-30 cl / 10 OZ
BIO800200PPT
1500



COUVERCLE BLANC CPLA

White lid CPLA
Tapa CPLA



-
BIO808200
1000 (10x100)



Les gobelets en carton
avec couché en CPLA,
pour les boissons chaudes,
entièrement compostables
et biodégradables.

Gobelet double paroi

nouveau

Pause café

Utilisation froide ou chaude



800673



800673



800673



8460010

GOBELET CARTON ONDULÉ PAROIS NOIRE 4OZ

Glass cardboard NOIRE 4oz Ripple ParoisVaso cartón ondulé Parois NOIRE 4 OZ



10 cl - 4 OZ



800671



2000 (50X40)



GOBELET CARTON ONDULÉ PAROIS NOIRE 10OZ

Glass cardboard NOIRE 10oz Ripple ParoisVaso cartón ondulé Parois NOIRE 10 OZ



27 cl - 10 OZ



800673



1200 (30X40)



GOBELET CARTON ONDULÉ PAROIS NOIRE 6OZ

Glass cardboard NOIRE 6oz Ripple ParoisVaso cartón ondulé Parois NOIRE 6 OZ



17 cl - 6 OZ



800672



1200 (30X40)



TASSE CAFE PS TRANSPARENT INJECTE

PS transparent coffee cup (injection moulded)
Taza de café PS transparente inyección



10 cl



8460010



300 (12X25)



Dimensions
Dimensions



Capacité
Capacity



Référence
Reference



Conditionnement
Packaging

Nouveauté «Ballon de Rugby»

Lancez-vous dans l'aventure !

Gobelet en forme de ballon de rugby.
Idéal pour les événements sportifs liés au rugby.
Ce gobelet est en polypropylène et est réutilisable et lavable en machine.
Convient pour les soft drinks ou pour 50 cl de bière.
Ce verre possède un bouchon qui peut se retirer.

Parfait pour communiquer, il est personnalisable avec votre logo en 3 couleurs à partir de 1000 pièces.



891557



personnalisable

Les +

- › Lavable machine
- › Réutilisable
- › Personnalisable
- › Identification de la contenance
- › Esthétique innovante (forme de ballon de rugby)
- › Bouchon clipsable

Gobelet réutilisable rugby 57 cl - 1 pint + couvercle
Reusable cup rugby
Rugby del vaso reutilizable



155X110 MM - 57 cl /
1 pint
891557
90

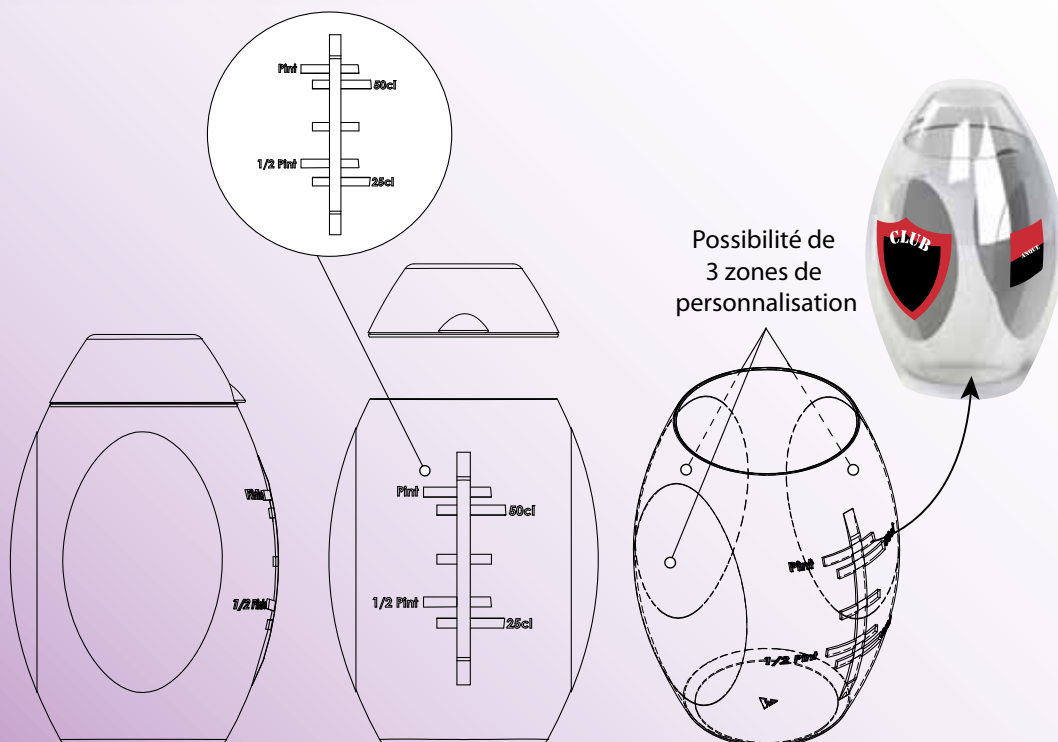

Verres

réutilisable

Collection «réutilisable»



8911033

8914026

8911060

8911033PPT

8911033PPT

8410004

VERRE CONSIGNÉ PP 33 CL - LIGNÉ 25/30 CL

Returnable PP glass lined 25/30 cl
Vaso retornable PP 25/30 cl



25/30 cl
8911033
300 (15x20)

personnalisable



GOBLET PP INJECTÉ LIGNÉ 60CL (LIGNÉ 40 ET 50 CL)

PP glass
Vaso glaçe PP



60 cl (ligné 40-50cl)
8911060
300 (15x20)



VERRE «TUBO» PP GIVRÉ 26 CL (LIGNÉ 0,4 CL)

Frosted PP «TUBO» glass
Vaso «TUBO» PP mate



26 cl
8914026
100 (10x10)

personnalisable



VERRE CONSIGNÉ DÉCOR PPT LIGNÉ 33CL

Returnable PP glass with decoration
Vaso retornable decorado PP



33 cl (ligné 25-30cl)
8911033PPT
300 (15x20)



VERRE À WHISKY COULEUR PS

PS coloured rocks glass
Vaso de whisky de colores PS



25 cl
971PCR/V/B
50



réutilisable

sur commande
to order / de encargo

VERRE À VIN PS

PS wine glass
Copa de vino PS



20 cl
8410004
48

sur commande
to order / de encargo



Dimensions
Dimensions



Capacité
Capacity



Référence
Reference



Conditionnement
Packaging

Verres réutilisables

réutilisable

NOUVEAU

Collection en «Tritan»



867007

8410004

867006



8610023

863023

8630012

Le copolyester Tritan a un aspect identique au verre véritable mais sans risque de casse :

Matière PS et polypropylène.

Tous sont garantis sans bisphénol A, ils sont également 100% recyclables.



- Incassable (Résistance aux chocs + 3 Tonnes)
- Transparence & brillance
- Durabilité (+ 3 000 lavages machine) sans ternissement

Il répond à toutes les exigences pour un produit de qualité :

- Sans BPA
- 100 % recyclable
- Incassable
- Résistant à haute température
- Résistance thermolyse
- Utilisations répétées

Shooter «Classic»



Shooter «Classic»
Shooter «Classic»

 H 53 mm - 4/4,7 cl
 867007
 x 500



Flûte «Grand cru»



Flute «Grand cru»
Flauta «Grand cru»

 H 190 mm - 13/16 cl
 863023
 x 35



Tumbler Standart



Tumbler Standard
Vaso Estándar

 H 152 mm - 22/23 cl
 862023
 x 48



Verre à pied «Sky»



Goblet «Sky»
Shooter «Classic»

 H 169 mm - 25/30 cl
 8610030
 x 25



Shooter «Tulipe»



Shooter «Tulip»
Shooter «tulipán»

 H 71 mm - 4/6 cl
 867006
 x 336



Flûte «Events»

Flute «Events»
Flauta «Eventos»

 H 162 mm - 10/12 cl
 8630012
 x 24



Verres réutilisables

NOUVEAU

Collection en «Tritan»



8650025



8660037



8650034



8660039



8640029



8630031



8640046

Verre «Whisky»
«Whisky» glass
Vidrio «Whisky»



H 81 mm - 22/25 cl



8650025



x 48



Verre à vin «Cabernet»
wineglass «Cabernet»
Vaso «Carbenet»



H 215 mm - 43/47 cl



8640029



x 12



Verre à eau
Glass for water
El vidrio soluble



H 100 mm - 30/37 cl



8660037



x 48



Mojito M
Mojito M
Mojito M



H 98 mm - 25/31 cl



8640031



x 48



Verre «Diamond»
«Diamond» Glass
«Diamante» de cristal



H 100 mm - 30/34 cl



8650034



x 24



Mojito XL
Mojito XL
Mojito XL



H 120 mm - 33/43 cl



8640046



x 48



Verre «Aqua» S
Glass 'Aqua' S
Cristal 'Aqua' S



H 100 mm - 30/39 cl



8660039



x 24



Produits personnalisables !

Impression 1 / 2 / 3

Dans les articles choisis,
impression en TAMPOGRAPHIE,
NUMERIQUE ou OFFSET

Tout est réalisable - consultez-nous !



Dimensions
Dimensions



Capacité
Capacity



Référence
Reference



Conditionnement
Packaging



Verres réutilisables

NOUVEAU

Collection en «Tritan»



810001



810001



8100010



810001



8690042

Vasque Prestige 6 bouteilles 11 L avec pied
Prestige Vessel 6 bottles 11 L with foot
Lavabo de lujo con 6 botellas de 11 L pies
Polycarbonate



H 195 mm - 6 bouteilles - 11 L
810001
x 1



Seau à champagne 1 bouteille transparent
Champagne bucket
Ramo de hielo
Polycarbonate



H 270 mm - 3,25 l
810000
x 4



Mug 40/42 cl
Mug
Jarra



H 102 mm - 40/42 cl
8690042
x 56



Carafe «Summertime» 2,2 L
Carafe «Summertime»
Jarra «verano»



H 130 mm - 2.2 L
8100022
x 1



Carafe «Epsilon» 1 L
Carafe «Epsilon»
Jarra «Epsilon»



H 226 mm - 1 L
8100010
x 4



Dimensions
Dimensions



Capacité
Capacity



Référence
Reference



Conditionnement
Packaging

Bouteilles



800043J/C



8000430/C1



8245250



800040/C1



800041



800042/C



250910

BOUTEILLE PLASTIQUE MELKA 250 ML LISSE

250ml plastic bottle melka smooth
250ml botella plástica lisa melka



250 ml
800040/C
181



BOUTEILLE PLASTIQUE MELKA 500 ML LISS

250ml plastic bottle melka smooth
250ml botella plástica lisa melka



500 ml
800041/C
136



CAPSULE POUR BOUTEILLE FRUITA EN PP ORANGE

Bottle cap fruit in orange
Fruta tapa de la botella de v naranja



-
8000430/C1
200



BOUTEILLE PLASTIQUE PET POUR JUS 1 LITRE

plastic bottle pet for 1 liter juice
mascota botella de plástico de 1 litro de jugo



1 L
800042/C
91



CAPSULE POUR BOUTEILLE FRUITA EN PP JAUNE

Bottle cap fruit in yellow
Cierre de botellas de frutas v AMARILLO



-
800043J/C
200



BOUTEILLE BOULE PET TRANSPARENT BAGUE À VIS 250 ML LISSE

250ml plastic bottle melka smooth
250ml botella plástica lisa melka



250 ml
8245250
400



nouveau

personnalisable

SAC À BOUTEILLE KRAFT BRUN POIGNÉES TORSADÉES

plastic bottle pet for 1 liter juice
mascota botella de plástico de 1 litro de jugo



11x11x39 mm
250910
20



Dimensions
Dimensions



Capacité
Capacity



Référence
Reference



Conditionnement
Packaging

Serviettes et nappes

Serviette écologique
Serviette non tissé
Serviette 2 plis
Serviette double points colorées
Serviette ouate blanche
Serviette et distributeur
Nappe rectangulaire
Nappe en rouleau
Chemin de table

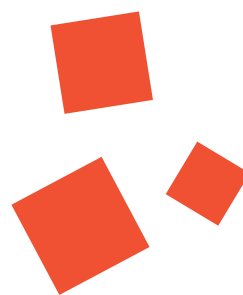

L'écologique

PERSONNALISATION

6132010 - mini : 54 000 pièces / 6132340 : 36 000 pièces

SERVIETTE MARRON CLAIR ÉCOLOGIQUE 1PLI

Towel BROWN GREEN 30 x 30 cm
servilletas maron claro ecológico 30 x 30



30 x 30 cm
611113/C
3200 (16x200)



SERVIETTE 100% RECYCLÉ KRAFT DOUBLE POINT

Towel 100% RECYCLED KRAFT
Servilleta donle punto reciclada kraft



6132113	330 x 330 mm Kraft / marron	360 (12x30)
6132313	380 x 380 mm Kraft / marron	900 (18x50)

Le must : serviettes « non tissé »

SERVIETTE 40 X 40 CM

Towel 40x40 cm
Servilletas 40 x 40 cm

612131/C	blanc / blanco	600 (12x50)
6121342	bordeaux / burdeos	600 (12x50)
6121322/C	champagne / champàn	600 (12x50)
6121383/C	bleu marine / azul marino	600 (12x50)
	autres coloris (nous contacter)	

Êtes-vous sûr que ce n'est pas du tissu ?

Souplesse, douceur et résistance, hyper absorbant, tenue inégalée, aspect et touché textile.
Vous cherchez d'autres coloris ?
N'hésitez pas à nous consulter !



Vous cherchez des idées pour décorer vos tables ?
Découvrez notre site www.axho.com



Dimensions
Dimensions



Capacité
Capacity



Référence
Reference









Conditionnement
Packaging

Serviettes et nappes

Serviettes «2 plis»

De toutes les matières...

SERVIETTE 30 X 30 CM
TOWEL 30 x 30 Cm
SERVILLETAS 300 x 300 MM









Code couleur	Code produit	Couleur	Quantité
	6112141	rouge / rojo	3000 (30x100)
	6112142	bordeaux / burdeos	3000 (30x100)
	6112121	ivoire / marfil	3000 (30x100)
	6112123	jaune maïs / maíz amarillo	3000 (30x100)
	6112194	bleu marine / azul oscuro	3000 (30x100)
	6112194	bleu clair / azul claro	3000 (30x100)

... c'est la ouate qu'elle préfère !

Un grand classique au rapport qualité prix imbattable. Très absorbante, bonne tenue, volume et douceur. Existe en 30x30 et 40x40 cm. Autres coloris, nous consulter.

SERVIETTES 38 X 38 CM / TOWEL 30 X 30 CM / SERVILLETAS 38 X 38 CM

* sur commande
to order / de encargo

Code couleur	Code produit	Couleur	Quantité
	6112321/C	ivoire / marfil	2400 (24x100)
	6112322*	chocolat / chocolate	1200 (24x50)
	6112323/C	jaune vif / amarillo	2400 (24x100)
	61123231	jaune paille/ amarillo	2400 (24x100)
	6112332/C	saumon / salmon	2400 (24x100)
	6112341/C	rouge / rojo	2400 (24x100)
	6112381	turquoise / tuquesa	2400 (24x100)
	6112383/C	bleu vif / azul brillante	2400 (24x100)
	6112384	parme / malva	2400 (24x100)
	6112387	bleu caraïbe / azul	2400 (24x100)
	6112393/C*	vert foncé / verde oscuro	2400 (24x100)



Serviettes et nappes



Serviettes double points colorées

C'est la ouate...

SERVIETTE COCKTAIL 20 X 20 CM
COCKTAIL TOWEL 20 X 20 CM
SERVILLETAS DOBLE PUNTO

personnalisable



	6132010	blanc / blanco	3000 (30x100)
	6132011	noir / negro	3000 (30x100)



Le double point :













Volume et douceur. C'est une serviette en ouate qui grâce à son gaufrage sur toute la surface lui confère une qualité très absorbante et une bonne tenue, volume, douceur. Un carnaval de couleurs pour un grand classique de la serviette papier.

SERVIETTE 38 X 38 M / SERVILLETAS DOBLE PUNTO



personnalisable

* sur commande
to order / de encargo

	6132340/C	blanc / blanco	1200 (24x50)				
	6132345	bleu marine / azul marino	1200 (24x50)		6132393/C* vert foncé / verde oscuro	1200 (24x50)	
	6132346	saumon / salmón	1200 (24x50)		6132348	chocolat / chocolate	1200 (24x50)
	6132341/C	rouge / rojo	1200 (24x50)		61323931*	vert amande / almendra	1200 (24x50)
	6132342/C	bordeaux / burdeos	1200 (24x50)		6132323	jaune / yellow	1200 (24x50)
	6132343	noir / negro*	1200 (24x50)		6132349	vert anis / verde	1200 (24x50)



Dimensions
Dimensions



Capacité
Capacity



Référence
Reference



Conditionnement
Packaging

Serviettes et nappes

Nappes rectangulaires «non tissé» 25 et 50 m

















Les nappes

NAPPE RECTANGULAIRES 1,20 X 25 M

MANTEL «VOIE SÈCHE» EN ROLLO / RECTANGULAR TABLECLOTH 1,20 X 25 M

* sur commande
to order / de encargo

Conditionnement : à l'unité

			
 632100	blanc / blanco	 632113	aubergine / berenjena
 632105	mandarine / mandarine	 632114	cacao / cacao
 632106	grège / crudo	 632116	turquoise / tuquesa
 632107	champagne / champan	 632115	parme / malva
 632109	prune / ciruela	 632117*	fushia / fucsia
 632111	gris / gris	 632122*	jaune vif / amarillo
 632112	noir / negro	 632123	rouge / rojo
		 632124	bleu marine / azul oscuro





NAPPES RECTANGULAIRES 1,20 X 50 M / MANTEL «VOIE SÈCHE» EN ROLLO / RECTANGULAR TABLECLOTHS 1.20 X 50 M

Conditionnement : à l'unité

			
 632201	blanc / blanco	 632207	champagne / marfil
 632202	rouge / rojo	 6322031VP	vert kiwi / verde
 632204/C	bordeaux / burdeos	 632296	cacao / cacao
 632206	bleu foncé / azul oscuro		

NAPPES VOIE SÈCHES RONDES Ø 240 CM / TABLECLOTHS DRY ROUNDS 1.20 X 50 M
MANTEL «VOIE SÈCHE» EN ROLLO

* sur commande
to order / de encargo

					
 632820*	blanc / blanco	12	 632824*	vert pomme / verde	12
 632821*	champagne / marfil	12	 632825*	cacao / cacao	12
 632822*	bordeaux / burdeos	12	 632826*	noir / negro	12



Serviettes et nappes

Les chemins de table



Vous aimez nos idées déco ?
Toutes nos créations sur le site www.axho.com



Les chemins de table voie sèche 0,30 x 10 m / Table runners dry 0,30 x 10 m / caminos de mesa secan 0,30 x 10 m

3660667023650	blanc / blanco	3660667023827	fushia / fucsia
3660667023667	ivoire / marfil	3660667023773	rouge / rojo
3660667023834	chocolat / chocolate	3660667023728	bordeaux / burdeos
3660667023711	tilleul	3660667023872	noir / negro
3660667023797	orange		

Les chemins de table voie sèche 0,40 x 10 m / Los centros de mesa / Caminos de mesa secan 0,40 x 10 m

622902*	champagne / champagne / champan 4	632503	rose 4
632501	cacao / cocoa / cacao 4	632504	bleu ciel/ blue / azul 4
632500	vert kiwi / green / verde 4	632505	gris perle / grey / gris 4
632502	parme / parma / malva 4	632506	noir / negro 4

* sur commande
to order / de encargo

Les sets papier 30 x 40 cm / The paper sets 30 x 40 cm / Tos sets papel

623101	blanc / blanco 1000	623127*	parme / malva 1000
623111	kraft brun / marron 500	623128	fuchsia / fucsia 1000
623141/C	rouge / rojo 1000	623129	prune / ciruela 1000
623123/C	jaune vif / amarillo 1000	623132/C*	abricot / albaricque 1000
623122	chocolat / chocolate 1000	623142/C	bordeaux / burdeos 1000
623125	vert amande / verde 1000	623143	gris / gris 1000
623126	mandarine / mandarín 1000	623191	vert foncé / verde 1000

* sur commande
to order / de encargo



Serviettes et nappes



611111/C



611211



611221/C



611231/C



611331

SERVIETTE OUATE BLANCHE

WHITE CELLULOSE SERVIETTES - SERVILLETAS GUATA BLANCAS

SERVIETTE 30x30 CM - 1 PLI

1-ply serviette
Servilleta 1 capa



30x30 cm
611111/C
4000 (20x200)



SERVIETTE 30x40 2 PLIS

2-ply serviette
Servilleta 2 capas



30x40 cm
611221/C
2400 (24x100)



SERVIETTE 30x30 2 PLIS

2-ply serviette
Servilleta 2 capas



30x30 cm
611211
3200 (32x100)



SERVIETTE 40x40 2 PLIS

2-ply serviette
Servilleta 2 capas



40x40 cm
611231/C
2400 (24x100)



SERVIETTE 40x40 3 PLIS

3-ply serviette
Servilleta 3 capas



40x40 cm
611331
1800 (36x50)

sur commande
to order / de encargo



Serviettes et nappes



SE2530B



SE3333D



611112/C1



611221D/C



XCPS12



XCPS13



K89310/C



T221063

SERVIETTE & DISTRIBUTEUR

SERVIETTES & DISPENSERS - SERVILLETAS Y DISTRIBUIDORS

SERVIETTE 25x30 1 PLY POUR DISTRIBUTEUR

1-ply serviette for dispenser
Servilleta 1 capa



25x30 cm



SE2530B



10800(36x300)



SON DISTRIBUTEUR

Serviette dispenser for SE2530B
Dispensador para SE2530B



XCPS12



1



SERVIETTE 30x30 1 PLY DÉCALÉ

2-ply serviette
Servilleta 1 capa



30x30 cm



611112



3000



SON DISTRIBUTEUR

Serviette dispenser for 611112
Dispensador para 611112



0611001



1



SERVIETTE 33x33 1 PLY DÉCALÉ POUR DISTRIBUTEUR

1-ply serviette for dispenser
Servilleta 1 capa para dispensador



30x33 cm



SE3333D



4000(16x250)



SON DISTRIBUTEUR

Serviette dispenser for SE2530B
Dispensador para SE2530B



XCPS13



1



SERVIETTE 30x40 2 PLIS

2-ply serviette
Servilleta 2 capas



30x40 cm



611221D/C



4000



SON DISTRIBUTEUR

Serviette dispenser for 6110211
Dispensador para 6110211



T221063



1



Dimensions
Dimensions



Capacité
Capacity



Référence
Reference



Conditionnement
Packaging

Serviettes et nappes



Les nappes papier blanc carré / rectangle 60, 70 et 80 cm

The white paper tablecloths square / rectangle 60, 70 and 80 cm

Rectangle 60, 70 and 80 cm Los manteles papel blanco cuadradas y rectángulos

NAPPE 60 X 60 CM

MANTEL 60 X 60 CM

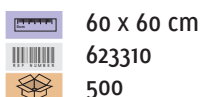

60 x 60 cm

623310

500

NAPPE 70 X 70 CM

MANTEL 70 X 70 CM



70 x 70 cm

623510

500

NAPPE 80 X 120 CM

MANTEL 80 X 120 CM

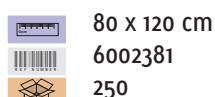

80 x 120 cm

6002381

250



Les nappes papier blanc rondes Ø 80, 90, 100, 110 et 120 cm

The round white paper tablecloths Ø 80, 90, 100, 110 and 120 cm

Los manteles de papel blancas redondas Ø 80, 90, 100, 110 y 120 cm

* sur commande
to order / de encargo

NAPPE Ø 80 CM

MANTEL



Ø 80 cm

652110

250

NAPPE Ø 90 CM

MANTEL



Ø 90 cm

652210

250

NAPPE Ø 100 CM

MANTEL



Ø 100 cm

652310*

250

NAPPE Ø 110 CM

MANTEL

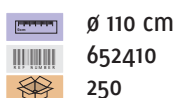

Ø 110 cm

652410

250

NAPPE Ø 120 CM

MANTEL

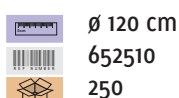

Ø 120 cm

652510

250

Serviettes et nappes

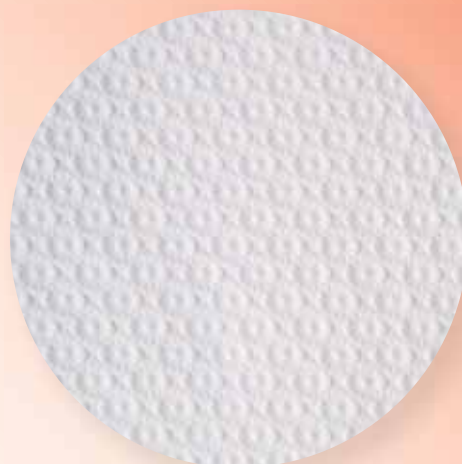
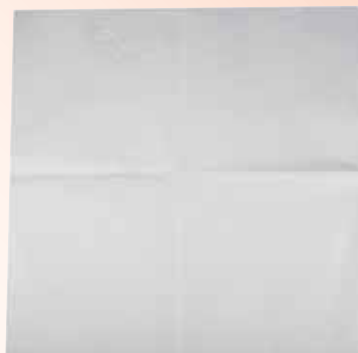

NAPPE BLANCHE EN ROULEAU

WHITE PAPER TABLE COVERS REELS - MANTEL PAPEL BLANCO EN ROLLO

NAPPE PAPIER BLANCHE EN ROULEAU

White paper table cover reel - Mantel papel blanco en rollo

<input type="checkbox"/>	20508	rouleau 1.20x10 m	25
<input type="checkbox"/>	603330/C	rouleau 1.18x50 m	8
<input type="checkbox"/>	603332/C	rouleau 1.18x100 m	4



NAPPE FORMAT BLANC

WHITE PAPER FORMATS - MANTEL FORMAS BLANCO

FORMAT PAPIER BLANC

White paper format - Formas papel blanco

<input type="checkbox"/>	623310	carré - 60x60	500
<input type="checkbox"/>	623510	carré - 70x70	500
<input type="checkbox"/>	6002381	rectangle - 80x120	250
<input type="checkbox"/>	652110	rond - Ø 80 cm	250
<input type="checkbox"/>	652210	rond - Ø 90 cm	250
<input type="checkbox"/>	652410	rond - Ø 110 cm	250
<input type="checkbox"/>	652510	rond - Ø 120 cm	250



Solution Transport

Plateau écologique
Boîte hamburger kraft brun
Caisse traiteur
Plateau réception
Plateau pour flûte champagne
Plateau verrines super-posable
Boîte de transport
& calage de verrines
Sac cabas kraft blanc & brun



Solutions transport

PLATEAU «Earth Tray»

LE CHOIX ÉCOLOGIQUE

Montrez votre engagement pour l'environnement

Vous désirez un plateau de qualité avec lequel vous pouvez aussi supporter l'utilisation des matières premières renouvelables ? Le Earth Tray est le premier plateau de haute qualité composé de 90% de matériel renouvelable.

Ce plateau est fabriqué avec 70 % de carton FSC dur et de 20% de résine de bio déchets.

- 90% écologique
- Résistant aux lave-vaisselles



11PL4232G



11PL4232L





11PLW4222D



PLATEAU SERVICE WAVE existe en 2 coloris gris et bois clair

*SERVICE TRAY WAVE
Available in 2 gray and light wood colors*

*SERVICIO DE BANDEJA DE ONDA
disponible en 2 colores de madera de color gris y la luz*

 42 X 32 X 25 mm
 11PL4232G
 X 25





 42 X 32 X 25 mm
 11PL4232L
 X 25



PLATEAU SERVICE TRAY WAVE bois foncé

*PLATEAU SERVICE WAVE
dark wood*

*SERVICIO DE BANDEJA DE ONDA
madera oscura*

 42 X 22 X 25 mm
 11PL4W4222D
 25



- Bonne prise en main grâce à ses bords fluides.
- Look unique et élégant.



Dimensions
Dimensions



Capacité
Capacity



Référence
Reference



Conditionnement
Packaging

Solutions transport

EMBALLAGE «FAST FOOD»



333120KR



334100



334100/C

BOÎTE HAMBURGER KRAFT BRUN 120X120X95 CM

All-purpose cardboard hamburger box

Caja cartón para hamburguesa



120 x 120 x 95 mm

333120KR

250



BOÎTE HAMBURGER KRAFT BRUN 97X97X61 CM MICRO CANELURE

All-purpose cardboard hamburger box

Caja cartón para hamburguesa



110 x 104 x 75 mm

334110/C

510



BOÎTE HAMBURGER KRAFT BRUN 97X97X61 CM MICRO CANELURE

All-purpose cardboard hamburger box

Caja cartón para hamburguesa



97 x 97 x 61 mm

334100/C

720



Toutes nos solutions burger dans le catalogue nomade !



Solutions transport



PLATEAUX « RÉCEPTION »



Idéal pour la présentation de pâtisseries et gâteaux sucrés ou salés tels les entremets, tartes, quiches, pizzas... Ce plateau est recyclable.



PLATEAU CARTON OR

Gold cardboard tray - bandeja cartón dorada



 280 x 190 mm
 820105
 100

 280 x 420 mm
 820101/c
 100





PLATEAU CARTON ARGENT

Silver cardboard tray - bandeja cartón plateada

 100 x 160 mm
 820107
 50

 280 x 190 mm
 820104
 100

 280 x 420 mm
 820106
 100



Dimensions
Dimensions



Capacité
Capacity



Référence
Reference



Conditionnement
Packaging

Solutions transport

Collection «Nect'Art»

PLATEAU «FLÛTES»

Disposez vos flûtes dans chacun des emplacements prévus à cet effet, servez et obtenez une présentation régulière et optimale.



0915035

8420151

8430031

«LE SUPER-POSABLE»





0915030

8430001T

PLATEAU PRÉSENTATION 20 VERRES/FLUTES

Display tray for 20 glasses/flutes

Bandeja para 20 vasos/copas de champán



 360 x 255 x 20 mm
 0915035
 60 (10x6)



PLATEAU PRÉSENTATION 30 VERRINES [VENDU SANS VERRINES]

Display tray for 30 verrines (verrines sold separately)

Bandeja 30 vasitos (no incluidos)

 335x390 mm
 0915030
 48





Pour compléter ce plateau, nous vous proposons :

VERRE «CRISTAL» 20 cl POUR PLATEAU PRÉSENTATION

«CRISTAL» glass for display tray

Vaso «CRISTAL» para bandeja

 20 cl
 8430031
 200 (10x20)





Pour compléter ce plateau, nous vous proposons toutes nos verrines p.28 :

VERRINE 5TH AVENUE TRANSPARENTE

PS «5TH AVENUE» transparent verrine

Vasito «5TH AVENUE» PS transparente



 7cl
 8430001T
 300 (10x30)



FLÛTE CRISTAL 15 cl POUR PLATEAU PRÉSENTATION

«CRISTAL» flute for display tray

Copa de champán «CRISTAL» para bandeja

 15 cl
 8420151
 200 (10x20)



EMPILABLE

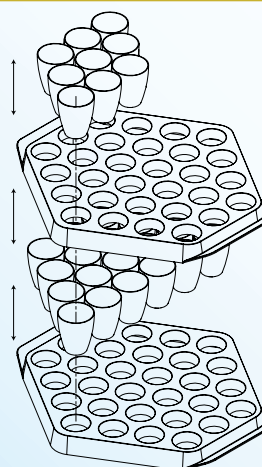

Solutions transport

CAISSES TRAITEUR

Ces caisses de transport sont à la fois robustes et pratiques grâce à leurs rebords. Idéal pour le transport de vos buffets, plateaux et caisses sur mesure.

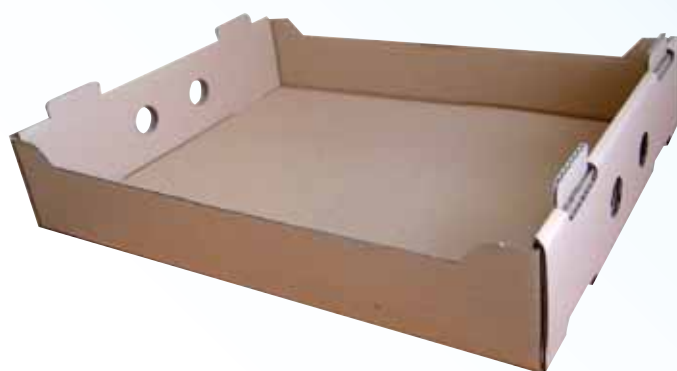

350336KB



350338KB

CAISSE TRAITEUR KRAFT BRUN

Catering box in brown cardboard
Caja comida preparada marrón



37 x 30 x 7 mm



350338KB



30



CAISSE TRAITEUR KRAFT BLANC

Catering box in white cardboard
Caja comida preparada blanca



66 x 45 x 10 mm



350336KB



30



Dimensions
Dimensions



Capacité
Capacity



Référence
Reference



Conditionnement
Packaging

Solutions transport

«LA BOÎTE DE TRANSPORT»

nouveau



120027



F5742

BOITE DE TRANSPORT

TRANSPORT BOX - CAJA TRANSPORTE

**BOITE DE TRANSPORT BLANCHE GRANDE CAPACITÉ
AVEC COUVERCLE ATTENANT MICRO CANELURE**

*White transport box with attached
Caja transporte blanca con tapa*



420x290x60 mm
120027
25



**BOITE DE TRANSPORT BLANCHE GRANDE CAPACITÉ
AVEC COUVERCLE ATTENANT MICRO CANELURE**

*White transport box with attached
Caja transporte blanca con tapa*



420x280x60 mm
F5742
25



Solutions transport



1200CAL35

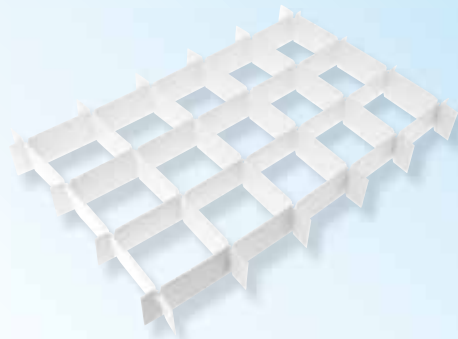

1200CAL15

CALAGE DE VERRINES

SETTING VERRINES - AJUSTE VERRINES

CALAGE 35 VERRINES

STALL 35 VERRINES

BLOQUEO 35 VERRINES



410x280x35 mm
1200CAL35
255 (17X15 CALAGES)

CALAGE 15 VERRINES

STALL 15 VERRINES

BLOQUEO 15 VERRINES



410x280x35 mm
1200CAL15
400 (16X25 CALAGES)

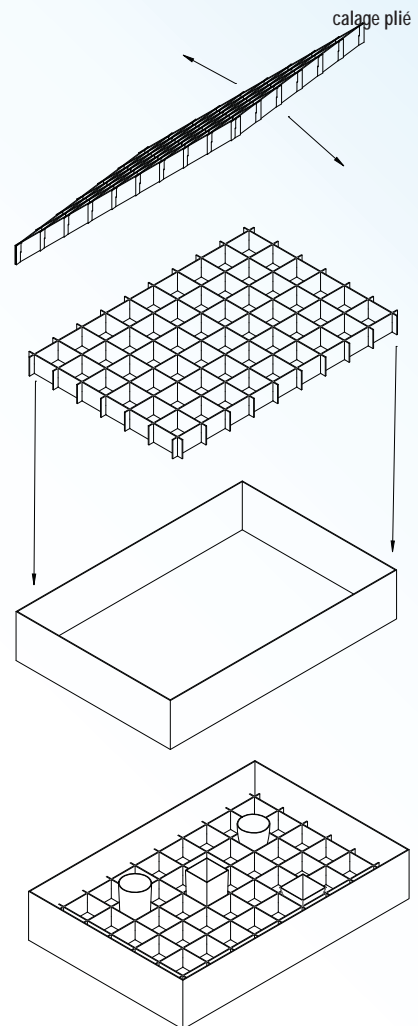

Dimensions
Dimensions



Capacité
Capacity



Référence
Reference



Conditionnement
Packaging

Solutions transport

Kraft blanc



10SA20B

7112625

10SA26B

7113224

7021412/C

702118

10SOSGBL

SAC CABAS

BAGS WITH HANDLES - BOLSITAS CON ASAS

personnalisable

SAC À EMPORTER SOS

TAKE-AWAY BAGS
BOLSITAS PARA LLEVAR

personnalisable

SAC CABAS KRAFT BLANC 20/10 CM

White bag with handles
Bolsa con asas blanca



SAC À EMPORTER KRAFT BLANC

White take-away bag
Bolsa blanca para llevar

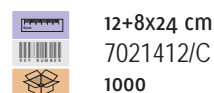

SAC CABAS KRAFT BLANC 26/14 CM

White bag with handles
Bolsa con asas blanca

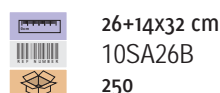

SAC À EMPORTER KRAFT BLANC

White take-away bag
Bolsa blanca para llevar



SAC CABAS KRAFT BLANC 26/18 CM

White bag with handles
Bolsa con asas blanca

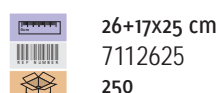

GRAND SAC À EMPORTER KRAFT BLANC

Large white take-away bag
Bolsa grande blanca para llevar



SAC CABAS KRAFT BLANC 32/20 CM

White bag with handles
Bolsa con asas blanca



nouveau

personnalisable

SAC À BOUTEILLE KRAFT BRUN POIGNÉES TORSADÉES

plastic bottle pet for 1 liter juice
mascota botella de plástico de 1 litro de jugo

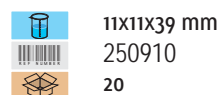

Capacité
Capacity



Référence
Reference



Conditionnement
Packaging

Solutions transport

Kraft brun



7122632

7113225KB

7123244



7112625KR



7113224KR

SAC CABAS

BAGS WITH HANDLES - BOLSITAS CON ASAS

personnalisable

SAC CABAS KRAFT BRUN 26/14 CM

Brown bag with handles
Bolsa con asas marrón

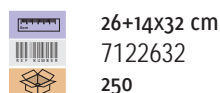

702413

702416

7221834

702414

SAC CABAS KRAFT BRUN 32/15 CM

Brown bag with handles
Bolsa con asas marrón

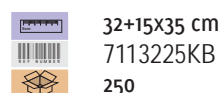

SAC À EMPORTER KRAFT BRUN

Brown take-away bag
Bolsa marrón para llevar

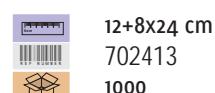

SAC CABAS KRAFT BRUN 32/16 CM

Brown bag with handles
Bolsa con asas marrón

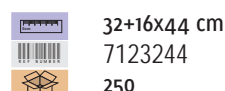

GRAND SAC À EMPORTER KRAFT BRUN

Large brown take-away bag
Bolsa grande marrón para llevar

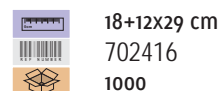

SAC CABAS KRAFT BRUN 26/18 CM

Brown bag with handles
Bolsa con asas marrón

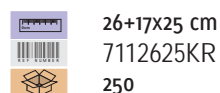

GRAND SAC À EMPORTER KRAFT BRUN

Large brown take-away bag
Bolsa grande marrón para llevar

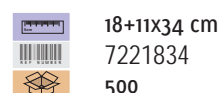

SAC CABAS KRAFT BRUN 32/20 CM

Brown bag with handles
Bolsa con asas marrón

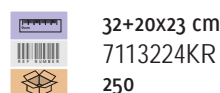

GRAND SAC À EMPORTER KRAFT BRUN

Large brown take-away bag
Bolsa grande marrón para llevar

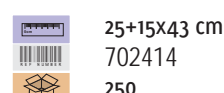

Dimensions
Dimensions



Capacité
Capacity



Référence
Reference



Conditionnement
Packaging

Solutions Doggybag

pour 1 ou 2 personnes

Cette solution est un système de transport de plats non terminés durant le repas effectué au restaurant. Idéal aussi pour un service de plat à emporter, la solution DOGGYBAG permettra aux restaurateurs de ne plus gaspiller, et aux consommateurs de se régaler même chez lui...

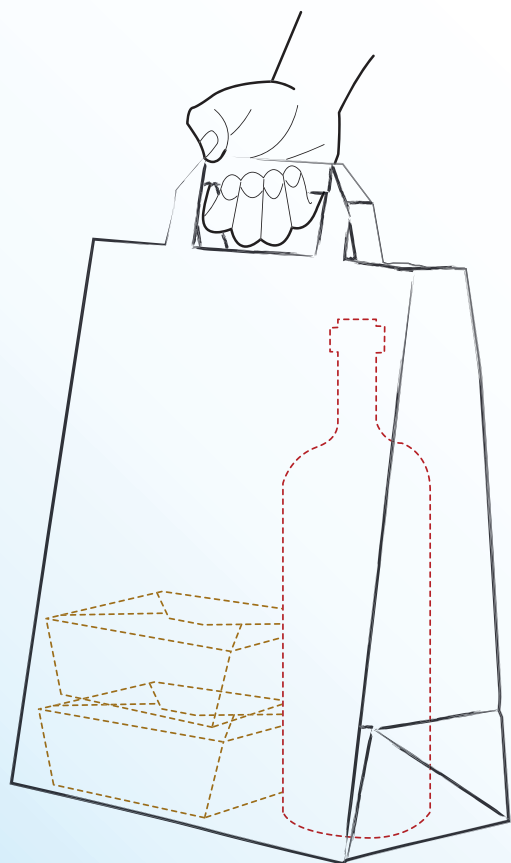

Assez du gaspillage?
ramener vos restes



Les +

- > Evite le gaspillage
- > Réduit les déchets chez le restaurateur
- > Adaptable selon les repas consommés sur place
- > Chauffe des aliments au four micro-ondes
- > Transport des produits simples et rapides
- > Simplicité d'utilisation
- > Etanchéité produit

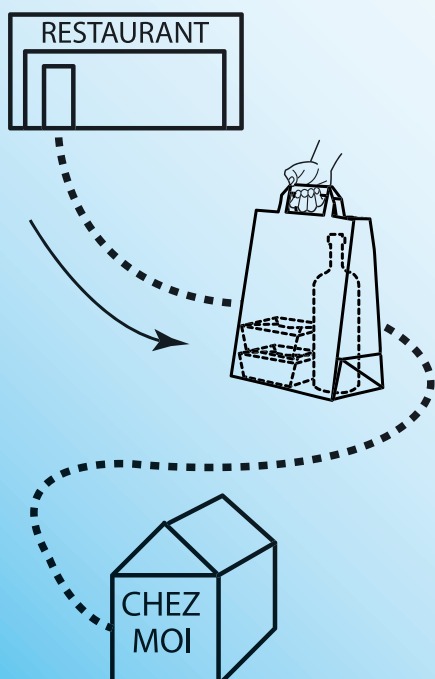

Solutions Doggybag

pour 1 ou 2 personnes

SOLUTION 1: Solution Doggybag pour 1 ou 2 personnes

Votre Logo
sur étiquette



Réf : 7122632
SAC CABAS kraft brun
260x140x320mm

A



- > FIRBIO
- > BIO1330130
- > 1 Barquette kraft brun 650ML par personne

B



Tenue de
soirée

- > Barquette PP
- > 3021000
- > 1 Barquette1000GR + couvercle par personne

SOLUTION 2 : Doggybag pour une bouteille

Votre Logo
sur étiquette



Réf : 250910
Sac à bouteille kraft brun
poignées torsadées
Dim. : 11x11x39mm
Paquets de 20



L'abus d'alcool est dangereux pour la santé.

Conception, fabrication & distribution

FIRPLAST LYON SERVICE COMMERCIAL

4 rue de Provence · 69800 SAINT PRIEST
Tél : 04 72 23 66 66 · Fax : 04 78 20 54 40
Mail : contact@firplast.com
www.firplast.com

Créé en 1983, Firplast est en mesure de vous proposer un service efficace et adapté grâce à ses structures, ses capacités techniques et ses moyens humains. Nous vous permettons à l'aide d'un franco étudié de gérer au mieux vos flux sans augmenter votre coût de stockage.

- Plus de 100 000 m³ de surface de stockage.
- Tous les articles présents dans le catalogue sont en stock.
- Procédure rapide de traitement des commandes jour A (par téléphone, fax, mail).
- Expédition des commandes jour B.
- Livraison par nos camions ou messagerie sous 48 à 72 h pour la France métropolitaine et sous 10 jours pour les autres pays européens.



Nous livrons le monde entier, n'hésitez pas à contacter notre responsable export pour toute question : export@firplast.com

Nos autres missions :

- **Solutions durables** et respectueuses de l'environnement pour particuliers et professionnels : contact@vision-verte.com
- **Conditionnement** adapté aux particuliers et à la grande distribution : contact@mes-verrines.com
- **Décoration à thème**, animation, et déguisements : contact@axho.com
- **Liaison froide** et **collectivités** : collectivite@firplast.com
- **Solutions transport** : nomade@firplast.com



Notre réseau

We deliver worldwide. Please contact our Export Manager for further information: export@firplast.com

Our other missions:

- **Sustainable solutions** that respect the environment, for end-customers and professionals: contact@vision-verte.com
- **Packaging** suitable for use by end-customers and large retailers : contact@mes-verrines.com
- **Themed decorations**, entertainment and fancy dress: contact@axho.com
- **Winter season community outreach and liaison**: collectivite@firplast.com
- **Transportation solutions**: nomade@firplast.com

Hacemos envíos a cualquier lugar del mundo. Si desea realizar alguna consulta, no dude en ponerse en contacto con nuestro departamento de exportaciones: export@firplast.com

Otros departamentos:

- **Soluciones sostenibles** y respetuosas con el medioambiente para particulares y profesionales: contact@vision-verte.com
- **Embalajes** para particulares y grandes empresas de distribución: contact@mes-verrines.com
- **Decoración temática**, actividades y disfraces: contact@axho.com
- **Línea fría y colectividades**: collectivite@firplast.com
- **Soluciones de transporte**: nomade@firplast.com

We invite you to visit our websites or to contact us directly. Our sales department will respond to your queries without delay.

Discover the whole range of our products and services on-line and download our catalogue in PDF format at: www.firplast.com/catalogues

No dude en visitar nuestras páginas web o en ponerse en contacto con nosotros. Nuestro departamento de ventas se pondrá en contacto con usted lo antes posible. Consulte todos nuestros productos en nuestras páginas web y la versión PDF de nuestro catálogo en : www.firplast.com/catalogues

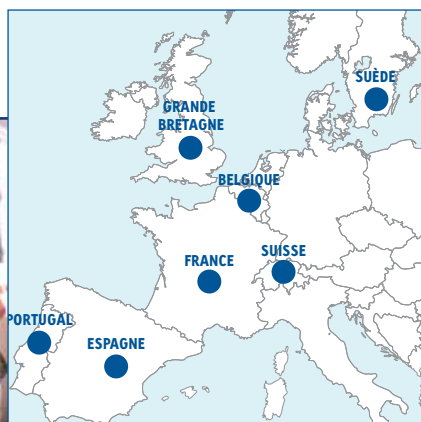

www.firplast.com



www.mes-verrines.com



Mes-verrines.com

www.vision-verte.com



www.axho.com



Dimensions
Dimensions



Capacité
Capacity















Référence
Reference



Conditionnement
Packaging

Informations techniques matières

	CODE	MATIÈRE	TEMPÉRATURE MINI / MAXI	MICRO-ONDABLE	FOUR TRADITIONNEL	COMPOSTABLE	BIODÉGRADABLE	RECYCLABLE
	PEUPLIER	Bois	-18°C à +220°C	NON	OUI	OUI	OUI	OUI
	PIN	Bois	-5°C à +70°C	NON	NON	OUI	OUI	OUI
	PULPE	Résidu canne à sucre	-18°C à +150°C	OUI	OUI	OUI	OUI	OUI
	BAMBOU	Pohaceae (herbacé)	-5°C à +70°C	NON	NON	OUI	OUI	OUI
	PLA TRANSPARENT	Plastique acide polyactique	-18°C à +40°C	NON	NON	OUI	OUI	OUI
	CARTON	—	-40°C à +80°C	OUI	NON	OUI	OUI	OUI
	APET - PET RPET - PETE	Polyéthylène teraphtalate	-40°C à +70°C	NON	NON	NON	NON	OUI
	PP	Polypropylène	-40°C à +120°C	OUI	NON	NON	NON	OUI
	PS	Polystyrène Thermoformé	-18°C à +80°C	NON	NON	NON	NON	OUI
	PSI	Injection Polystyrène	-18°C à +80°C	NON	NON	NON	NON	OUI
	VERRE	—	-36°C à +200°C	OUI	NON	NON	NON	OUI
	CÉRAMIQUE	—	-20°C à +80°C	OUI	OUI	NON	NON	NON

General terms of sale

1. APPLICATION OF THE GENERAL TERMS OF SALE - DEFINITIONS

(a) Any sale concluded and any order accepted by FIRPLAST (hereinafter «the Vendor») are governed by the special terms of sale featuring on the Vendor's offers, acceptances of orders or sales agreements as well as by these general terms of sale (which documents can only be modified in writing notwithstanding all stipulations to the contrary that may feature in the Buyer's special terms or general terms of purchase).

(b) The term «Products» signifies the products sold by the Vendor.

2. OFFERS

The Vendor's offers are made provided that the products offered are available on receipt of the Buyer's order.

3. ACCEPTANCE OF ORDERS

(a) Any order is reputed to be accepted by the vendor and represents a firm sale once the Products are handed to the carrier chosen by the vendor in the event this provides the transport of these or issued to the Buyer or its carrier if the Buyer provides the transport of the aforementioned Products.

(b) No firm sale can be cancelled by the Buyer.

4. DELIVERY – RISKS – TRANSPORT – RECEIPT

(a) The Products are delivered and Sold by the Vendor either free warehouse from the Buyer or ex warehouse of the Vendor if the Buyer provides the Transport of these. If the order does not reach the sum of the carriage paid provided in the special terms of sale, shipping gives rise to a fixed invoicing.

The products are shipped at the risks and perils of the Buyer although the transfer of property is deferred, in accordance with Clause 7 (property reservation) below.

(b) For sales free warehouse from the Buyer, the Vendor is responsible for shipping and insuring Products. The Vendor's intervention in determining or carrying out the shipping and insurance of Products on no account confers to the Vendor the capacity of freight forwarder or carrier.

(c) For sales ex warehouse from the Vendor, the Buyer is responsible for shipping and insuring the Products.

(d) IN THE EVENT THE PRODUCTS ARE SOLD FREE WAREHOUSE FROM THE BUYER, THE RECEIPT OF PRODUCTS BY THE BUYER CANCELS ANY CLAIM AGAINST THE VENDOR FOR DAMAGE OR MISSING ITEMS UNLESS THE BUYER NOTIFIES THE CARRIER OF ITS RESERVATIONS BY REGISTERED LETTER WITH ACKNOWLEDGEMENT OF RECEIPT WITHIN THREE DAYS (NOT INCLUDING SUNDAYS AND BANK HOLIDAYS) FOLLOWING RECEIPT OF THE PRODUCTS ACKNOWLEDGED BY THE RECEIPT ISSUED TO THE CARRIER AND THAT IT SENDS A COPY OF THIS NOTIFICATION TO THE VENDOR WITHIN THE SAME DEADLINE.

(e) In the event the Products are sold ex warehouse from the Vendor, the receipt of Products by the Buyer or its carrier at the Vendor's warehouse ends any claim against the Vendor for damage or missing items, unless this claim reaches the Vendor by registered letter with acknowledgement of receipt within three clear days (not including Sundays and bank holidays) following the said receipt of the Products.

(f) In the event of a «cash on delivery» delivery the Buyer must make out the cheque to FIRPLAST. On no account should the cheque be made out to the carrier.

(g) The products are delivered in standard packaging (cardboard or sachets) in different models each including a given Product unit number. If the number of product units ordered by the Buyer do not correspond to the number of units contained in any of the Vendor's standard packaging, the Vendor will deliver the nearest number of units depending on the packaging (more or less) and the Buyer will be obliged to accept the delivery of this at the price invoiced for the number of units considered, without being able to claim any indemnity from the Vendor. It is understood that if the number of units delivered is less than the number of units ordered for the reason indicated above, this difference can on no account represent a «missing item» in the meaning of paragraphs (d) and (e) above.

5. PRICE

The price of the Products will be that of the Vendor's rate in force on the delivery date. However, if this price exceeds the price in force on the order date by the Buyer by more than 10%, the Buyer can, by dispensation to Clause 3 above, cancel its order provided (a) that it returns all Products delivered to the Vendor beforehand and (b) that the aforementioned Products are in perfect selling condition. This Clause 5 will not apply to orders of Products on which special inscriptions («special print») or graphical motifs («artwork») must be affixed at the Buyer's request.

6. PAYMENT TERMS

(a) Unless stipulation to the contrary under the Vendor's special sales terms the price of Products is payable cash («cash on delivery») on receipt of the Products by the Buyer in its warehouses or their receipt by the Buyer or its carrier in the Vendor's warehouses if the Buyer provides transport.

(b) During an initial order a 50% part payment of the price of the Products thus in force is payable on order.

(c) In the event of non-payment of all or part of the price on its due date or non-acceptance of a bill of exchange, if necessary, the full price of the products and the balance remaining due will become, immediately and ipso jure, payable, wi-

thout a prior need to give notice or any legal proceedings and without prejudice to Clause 7 (property reservation) and Clause 10 (sale annulment) hereafter. Any amount or all or part of the price of the Products due by the Buyer and not paid on its due date bears interest ipso jure from this date and without notice, in favour of the Vendor, at a rate equal to three times the legal interest rate. With express agreement and unless a deferral requested in time and granted by FIRPLAST, any amount featuring on the invoice not paid on the due date immediately leads to ipso jure:

_ the payability of the following terms as well as any amount remaining outstanding,

_ the withdrawal of advantages that may have been previously agreed and notably the withdrawal of payment deadlines granted under special terms

_ the interruption of all deliveries underway or to come,

_ the right, for FIRPLAST, to take back goods already delivered and not paid for under the terms set out hereafter. In the event of recovery through legal action, the sums due could be increased by 15%, pursuant to the penalty clause in addition to possible legal costs.

Bills of exchange unpaid on their due date will be, furthermore, increased in the event of a new presentation, with interest and costs incurred by their return and the new release.

7. PROPERTY RESERVATION

THE PRODUCTS REMAIN THE PROPERTY OF THE VENDOR UNTIL FULL PAYMENT OF THEIR PRICE BY THE BUYER. THE BUYER ASSUMES THE RISKS OF ANY LOSS OR DAMAGE TO THE PRODUCTS ONCE THEY HAVE LEFT THE VENDOR'S WAREHOUSE. THE VENDOR WILL HAVE THE RIGHT TO TAKE BACK SOLD PRODUCTS BY SIMPLE NOTICE IF THEIR ENTIRE PRICE (VAT INCLUDED) HAS NOT BEEN PAID ON THE DUE DATE.

8. GUARANTEE

The guarantee of hidden defects of the Products by the Vendor is limited to the free replacement of the Products recognised to be faulty by the Vendor, subject to their correct use, excluding all damages, unless the guarantee granted to the Vendor by the manufacturer is less favourable, in which case, the latter alone will be applicable to the Buyer.

9. RESPONSIBILITY – DELIVERY LEAD TIME – FOREIGN CLAUSE

(a) The Vendor endeavours to deliver the Products to the Buyer as soon as possible. However, the lead times mentioned to the Buyer are for information only. The Vendor is therefore not responsible in the event of a delivery delay.

(b) In the event of a total or partial non-performance by the Vendor of its obligations, the manager of the Vendor will be limited to direct damage (excluding loss of revenue) endured by the Buyer due to this non-performance.

(c) The Vendor will not be responsible for the total or partial non-performance of its obligations if this non-performance results from a case of force majeure or a cause that is foreign to it and independent of its will even if this cause is not force majeure (such as, but this list is not exclusive, strike, lock-out, war, act of terrorism, fire, natural disaster, accident, embargo, requisition, nationalisation, legislative or statutory measures promulgated by government authorities).

10. SALE ANNULMENT

(a) Without prejudice to its rights according to Clause 6 (payment terms) or Clause 7 (property reservation) above, the Vendor can terminate the sale of the Products in the event of non-payment by the Buyer, on its due date, of the full or partial price and/or VAT relating to it or any other sum due.

(b) Without prejudice to its rights according to Clause 6 (payment terms) or Clause 7 (property reservation) above, the Vendor can terminate the sale in the event of non-performance by the Buyer of any one of its obligations vis-à-vis the Vendor or in the event of suspension of payments, compulsory liquidation, liquidation of assets, temporary suspension of proceedings or any similar proceedings, amiable dissolution by the Buyer or, generally, if it ceases its activity for any reason whatsoever.

(c) The sale annulment according to this Clause 10 will be obtained ipso jure immediately, by simple registered letter with acknowledgement of receipt, without notice or prior legal proceedings and the Vendor can repossess the Products subject of the annulled sale, without prejudice to claim any damages.

11. PRODUCT MODIFICATION

The Vendor reserves the right to modify the Products, including their composition and packaging, with the aim of providing improvements or to comply with regulations in force.

12. ORDER FILLING

The Vendor will not be obliged to honour the orders for Products (a) the production of which will have been definitively interrupted or that itself or one of the companies of its group no longer has the right to manufacture and/or Sell or (b) the delivery of which would become excessively costly following modifications to any regulation in force, French or foreign and/or (c) in the event the Vendor is in liquidation or has ceased all activity. In the previous cases, the Buyer can claim no damages from the Vendor.

13. JURISDICTION

In the event of a dispute relating to the sale of Products and all consequential legal proceedings, the Courts of LYON will alone have jurisdiction even in the event of a multiplicity of defendants or a third-party complaint and whatever the payment terms.



Condiciones generales de venta

1/ PREÁMBULO

Las presentes condiciones generales de venta son reputadas ser conocidas y aceptadas por el comprador. El hecho de hacer un pedido, de depositar un anticipo o de coger posesión implica la aceptación formal de los presentes que logras, de manera expés, sobre la del comprador, salvo excepcion escrita y previa de nuestra parte.

2/TARIFAS

La tarifa adjunta, no es en ningún caso, una enumeración exhaustiva de los productos distribuidos por firplast, que se reserva, a todo momento, el derecho de añadir, suprimir o modificar éstos.

La tarifa es susceptible evolucionar sin preaviso, a causa de que se trata para algunos, de productos extranjeros cuyo precio es propenso a variaciones de moneda.

3/PRECIOS

Nuestros precios se entienden netos, libres de impuestos y sin descuentos, a la salida del almacén.

La tarifa es repasable a cualquier momento. Las condiciones de un presupuesto o de una oferta de precios son limitadas por una fecha de opción más allá de la cual la sociedad firplast no se hace responsable. Los precios aplicables son éstos en vigor en caso de pedido y después de confirmación por firplast.

Sin embargo, esta convenido de que el comprador sufrira el exceso de variación monetaria más allá de una diferencia de cotización del 5% entre el valor de cotización del pedido y de la entrega y eso para las monedas del país de origen respectivo de los materiales importados.

4/RESERVA DE PROPIEDAD

Según la ley 67-563 del 13 de julio de 1967 [artículo 65] y a la ley 80-335 del 12 de mayo de 1980, la propiedad de la mercancía queda reservada a firplast hasta el pago completo del precio y de sus accesorios. Se ha acordado que la entrega de cheques o de efectos equivale a pago únicamente cuando éstos hayan sido pagados completamente.

De convención expresa entre los partidos, el comprador tiene por obligación en cuanto se reciba su entrega, de asegurarse para los riesgos de pérdida o de deterioración especialmente en caso fortuito o caso de fuerza mayor.

En caso de pérdida o deterioro, el comprador tiene obligación de pagar a Firplast los daños y perjuicios, de ahora en adelante fijados a la fracción del precio impagado durante la realización del riesgo.

De esta manera, queda por obligación asegurarse ante una compañía solvente.

La indemnidad de seguro será pagada a Firplast y le tocara al comprador completarla, si se presenta el caso para alcanzar el importe de daños y perjuicios fijados a continuación:

- El comprador se compromete en asegurarse contras los daños enlazados a la guardia de los materiales y mercancías considerados estropeados o padecidos por ellos.

- El comprador se compromete en sustituirse sobre los bienes y tal y cual fijados por Firplast, todos los elementos que permitan la identificación de éstos, particularmente las placas de constructor.

- Los bienes traspasados no podrán ser revendidos sin pago previo de la totalidad del precio convenido.

De convención expresa, y no obstante toda otra disposición contraria, todas las sumas que nos hayan sido pagadas a título de adelanto, de confirmación de pedido, por letra de cambio o siguiente toda otra denominación o forma, nos serán otorgados a título concertado, incluso en caso de que la mercancía entregada nos fuese restituida totalmente intacta.

5/ TRANSPORTE Y ENTREGA

Las mercancías son reputadas entregadas una vez dirigidas en el lugar de entrega previsto durante la toma de su pedido.

La expedición da lugar a facturación forfetaria de 17€ para todo pedido inferior a 380€.

Los pedidos superiores a esta suma son entregados porte pagado. En caso de pérdida, de avería o de daño sufrido por las mercancías, le pertenece al cliente mandar tanto a Firplast como al transportista, un constante, convincente en un plazo máximo de 48 horas.

6/ VUELTA DE MERCANCÍA

En caso de entrega reconocida defectuosa por Firplast, nuestra responsabilidad se limita al cambio de la mercancía constatada defectuosa, excluyendo toda indemnización en nombre de perjuicios eventuales padecidos.

7/ CONDICIONES DE PAGO

Para cualquier cliente que no posee una cuenta abierta en nuestros libros, el pago se hace al contado acuse del recibo. Cada demanda de apertura de cuenta debere ser acompañada para ser efectiva de un RIB [relevado d indentidad bancaria] y de un KBIS.

Salvo estipulación opuesta de nuestra parte, los clientes con cuenta, deben su pago a 30 días netos. Los pagos en cuenta se efectuan mediante cheque o letra de cambio no aceptada. Los efectos de comercio deben sernos restituidos bajo 8 días.

8/ DECADENCIA DEL PLAZO

De convención expresa en caso de retraso del plazo, de préstamo, de vuelta del efecto o de retraso de pago solo de una factura, y sobre simple intimación, por carta certificada, podremos exigirle con pleno derecho el pago inmediato de todas las sumas incluso no vencidas. La aplicación de la presente cláusula nos autoriza a aplazar a toda nueva entrega y a refusarle, para cualquier nuevo pedido, el beneficio de las condiciones de pago que hayan podido ser consentidas.

9/ CLÁUSULA PENAL

En caso de no pagar las facturas en un plazo de 30 días después de una intimación, por carta certificada con acuse de recibo, quedado sin efecto unos ocho días, el cliente deberá pagar a título de las cláusulas penales [en el sentido del artículo 1229 del código civil], una indemnidad concertada fijada a 20% de las sumas restantes debidas, particularmente para tener en cuenta la perturbación causada a la tesorería de su acreedor y gastos menudos y honorarios de cobro sin que el mínimo pueda ser inferior a 76€.

En este caso, cualquier suma que quede debida, sera exigible y los pedidos pendientes podrán ser anulados.

10/ OPOSICIÓN

En caso de oposición, los juzgados de la sede son únicos competentes, cualquier sean las condiciones de venta y el modo de pago aceptado, incluso en caso de apelación en garantía de la pluralidad de los defensores.



Dimensions
Dimensions



Capacité
Capacity



Référence
Reference



Conditionnement
Packaging

Nos collections - Our ranges - Nuestras gamas

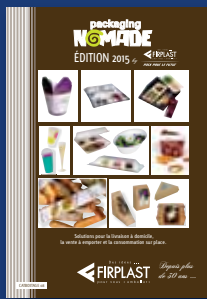

- Nomade -

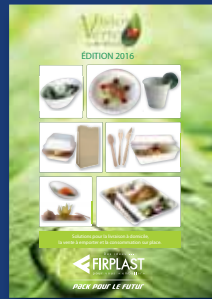

- Vision Verte -



- Collectivités -



- Gobeletterie -

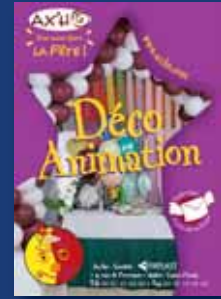

- Décoration -

Nos sites internet - Our websites - Nuestros sitios internet



www.firplast.com



www.vision-verte.com



www.interface-packaging.fr



www.axho.com



www.mes-verrines.com

FIRPLAST LYON

4, rue de Provence - 69800 ST-PRIEST
Tél. 04 72 23 66 66 - Fax 04 78 20 54 40
contact@firplast.com - www.firplast.com

FIRPLAST MARSEILLE

2 rue de Isaïa - Les Chutes Lavie - 13013 MARSEILLE
Tél. 04 96 13 06 50 - Fax 04 96 13 06 51

FIRPLAST LANGUEDOC

MIN de Montpellier - Boîte n°16 - 281, av. du Marché Gare
34070 MONTPELLIER
Tél. 04 67 58 34 00 - Fax 04 67 58 50 37

FIRPLAST BORDEAUX

Rue Jean Raymond Guyon Z.I. - 33310 LORMONT
Tél. 05 56 31 66 57 - Fax 05 56 74 60 42

ISÈRE EMBALLAGE société adhérente indépendante

32, avenue du Grugliasco - 38130 ECHIROLLES
Tél. 04 76 62 79 32 - Fax 04 76 24 44 32

LE SPÉCIALISTE

PME - PMI de Rivière Riche - Boîte 144 - 97200 FORT DE FRANCE - MARTINIQUE DE L'EMBALLAGE
Tél. 05 96 50 78 80 - Fax 05 96 50 56 55

GEREMBAL ANTILLES

APPRO EMBAL

Moundong Sud 97122 Baie Mahault - GUADELOUPE
Tél. 05 90 32 78 18 - Fax 05 90 32 78 08

PINESGA BUSINESS GROUP. SL

SABADELL - BARCELONA
Tél. +34 937457193 - Fax +34 937253799 - ESPAGNE

FIRPLAST - ECHO

MONTECATINI TERME - PISTOIA
Tél: +39 3389354923 - Mail: thomas@firplastitaly.it - ITALIA

